



电子微波元件

www.hnsmd.com hnsmd co.,Ltd

E-Mail: sales@hnsmd.com

Sale Phone:86-592-5713956





© 1999 www.daj.ne.jp

本期话题

第 8 代高性能 N 沟道功率 MOS FET.....	2
索引.....	3, 4
小信号晶体管.....	5, 6
小信号 FET.....	7
GaAs 线性 IC	
高频线性 IC.....	8
高频功率 MOS FET	
高频功率放大用.....	8
功率晶体管	
普通放大用.....	9
普通开关用.....	9

功率 MOS FET	
普通开关用.....	10, 11, 12
普通放大用.....	13
阵列.....	13
热 FET.....	13
IGBT.....	13
RF 功率组件.....	14
标准包装规格.....	14
封装.....	15
标志表示一览表.....	16

第八代高性能N沟道功率MOS FET

特点

- 在低电压驱动，是超低导通电阻。
HAT2164H 4.5 V RDS(on) = 3.0 mohm (typ)
- 高速开关 = 低Qgd
HAT2165H 4.5 V RDS(on) = 3.6 mohm (typ)
Qgd = 5.6 nC (typ)
- 小、薄型、低热阻封装LFAK
- 雪崩保证 (Avalanche rated)

优点

- 实现了电源的小、薄型化和高效率化。

外形尺寸图

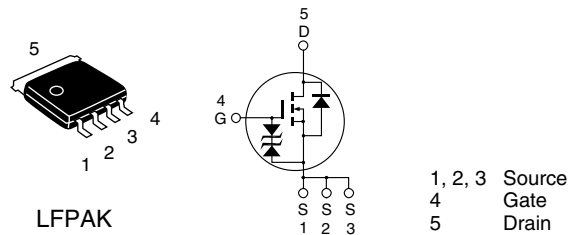
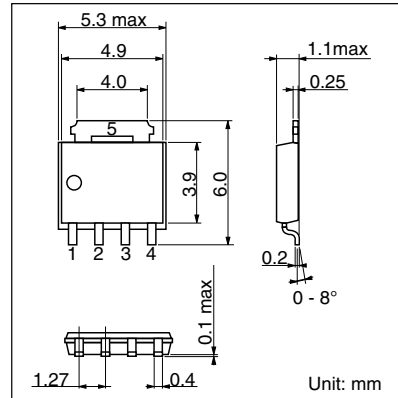

主要电特性

Type No.	Maximum Rating				RDS(on)(mΩ)				Qgd (nC)	Qg (nC)	Schedule		Note
	VDSS (V)	VGSS (V)	ID (A)	Pch (W)	VGS = 4.5V (7V)		VGS = 10V				WS	MP	
					typ	max	typ	max					
HAT2159H	20	±20	55	30	3.4	4.9	2.4	3.0	5.6	35	OK	10/02	Qg = VGS = 5V
HAT2160H			60	30	2.8	4.1	2.1	2.6	10	54	OK	10/02	Qg = VGS = 5V
HAT2161H			50	25	3.9	5.7	2.7	3.4	5.0	30	10/02	10/02	Qg = VGS = 5V
HAT2162H			40	20	5.9	8.6	4.0	5.0	3.1	19	OK	10/02	Qg = VGS = 5V
HAT2163H			30	15	8.6	12.5	5.7	7.1	2.0	12	OK	10/02	Qg = VGS = 5V
HAT2164H			60	30	3.0	4.4	2.5	3.1	15	60	OK	10/02	Qg = VGS = 5V
HAT2165H			55	30	3.6	5.3	2.6	3.3	5.6	35	OK	10/02	Qg = VGS = 5V
HAT2166H			45	25	4.2	6.1	3.0	3.8	5.0	30	OK	10/02	Qg = VGS = 5V
HAT2167H			40	20	6.4	9.3	4.4	5.5	3.1	19	OK	10/02	Qg = VGS = 5V
HAT2168H			30	15	9.3	13.5	6.3	7.9	2.0	12	OK	10/02	Qg = VGS = 5V
HAT2169H	40	±20	50	30	(3.8)	(5.2)	3.4	4.3	12	97	9/02	12/02	Qg = VGS = 10V
HAT2170H			45	30	(5.1)	(6.9)	4.5	5.6	6.8	62	9/02	12/02	Qg = VGS = 10V
HAT2171H			40	25	(6.1)	(8.3)	5.4	6.8	6.0	52	9/02	12/02	Qg = VGS = 10V
HAT2172H			30	20	(8.9)	(12.0)	7.8	9.8	4.0	32	9/02	12/02	Qg = VGS = 10V
HAT2173H	100	±20	25	30	(16.3)	(24)	14.2	17.8	14.5	78	OK	11/02	Qg = VGS = 10V
HAT2174H			20	25	(30)	(43)	26	32.5	7.5	40	OK	11/02	Qg = VGS = 10V
HAT2175H			15	20	(46)	(67)	40	50	5.0	28	OK	11/02	Qg = VGS = 10V

由于产品在开发中，有未事先通知而变更规格的情况。

Schedule: month/year

应用举例

● 通信设备电源

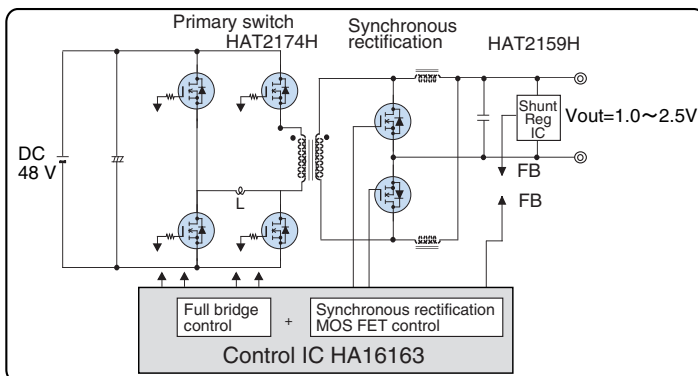

● 非绝缘型DC-DC变换器

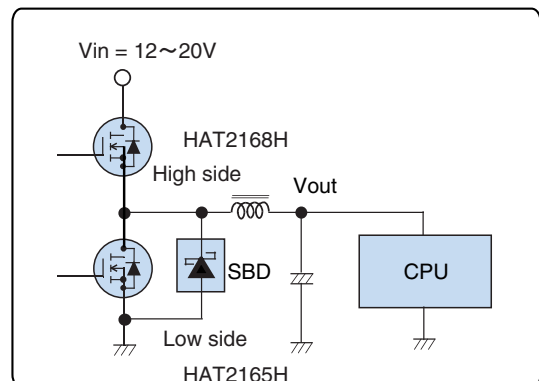

INDEX

■2SA series

Type No.	Package code	P
673	TO-92	5
673A	TO-92	5
673A(K)	TO-92	6
778(K)	TO-92	6
778A(K)	TO-92	6
836	TO-92	5
844	TO-92	5
872A	TO-92	5
893	TO-92	5
893A	TO-92	5
1029	TO-92	5
1030	TO-92	5
1052	MPAK	5
1082	TO-92	5
1084	TO-92	5
1085	TO-92	5
1121	MPAK	5
1122	MPAK	5
1171	MPAK	5
1188	TO-92	5
1190	TO-92	5
1191	TO-92	5
1193(K)	TO-92MOD	6
1374	SPAK	5
1390	SPAK	5
1484	MPAK	5
1566	MPAK	5
1617	MPAK	5
2080	CMPAK	5
2081	CMPAK	5

■2SB series

Type No.	Package code	P
561	TO-92	5
562	TO-92MOD	5
566(K)	TO-220AB	9
566A(K)	TO-220AB	9
647	TO-92MOD	5
647A	TO-92MOD	5
715	TO-92MOD	5
716	TO-92MOD	5
716A	TO-92MOD	5
727(K)	TO-220AB	9
738	TO-92MOD	5
739	TO-92MOD	5
740	TO-92MOD	5
791(K)	TO-220AB	9
831	MPAK	5
857	TO-220AB	9
858	TO-220AB	9
859	TO-220AB	9
860	TO-220AB	9
861	TO-220AB	9
955(K)	TO-220AB	9
1001	UPAK	6
1002	UPAK	6
1025	UPAK	6
1026	UPAK	6
1028	UPAK	6
1032(K)	TO-3P	9
1048	UPAK	6
1079	TO-3P	9
1091	TO-220AB	9
1103	TO-220AB	9
1389	TO-220FM	9
1390	TO-220FM	9
1391	TO-220FM	9
1392	TO-220FM	9
1399	TO-220FM	9
1400	TO-220FM	9
1407	DPAK	9
1409	DPAK	9
1494	TO-3P	9
1530	TO-220FM	9
1688	TO-92	5
1691	MPAK	5

■2SC series

Type No.	Package code	P
458	TO-92	5
458(K)	TO-92	6
458LG	TO-92	5
460	TO-92	6
461	TO-92	6
535	TO-92	6
1213	TO-92	5
1213A	TO-92	5
1213A(K)	TO-92	6
1214	TO-92	5
1344	TO-92	5
1345	TO-92	5
1345(K)	TO-92	6
1472(K)	TO-92	6
1515(K)	TO-92	6

■2SC series

Type No.	Package code	P
1775	TO-92	5
1775A	TO-92	5
1881(K)	TO-220AB	9
1890	TO-92	5
1890A	TO-92	5
1906	TO-92	6
1907	TO-92	6
1921	TO-92MOD	5
2308	TO-92	5
2309	TO-92	5
2310	TO-92	5
2396	TO-92	5
2462	MPAK	5
2463	MPAK	5
2471	TO-92	6
2512	TO-92	6
2543	TO-92	5
2544	TO-92	5
2545	TO-92	5
2546	TO-92	5
2547	TO-92	5
2610	TO-92MOD	5
2612	TO-220AB	9
2613	TO-220AB	9
2618	MPAK	5
2619	MPAK	6
2620	MPAK	6
2732	MPAK	6
2734	MPAK	6
2735	MPAK	6
2736	MPAK	6
2776	MPAK	6
2816	TO-220AB	9
2853	TO-92	5
2854	TO-92	5
2855	TO-92	5
2856	TO-92	5
2898	TO-220AB	9
2979	TO-220AB	9
3127	MPAK	6
3128	TO-92	6
3336	TO-3P	9
3365	TO-3P	9
3380	UPAK	6
3390	SPAK	5
3391	SPAK	5
3413	SPAK	5
3470	SPAK	5
3510	TO-92	6
3512	TO-92	6
3513	MPAK	6
3553	SPAK	5
3793	MPAK	6
3836	SPAK	5
3957	MPAK-4	6
4050	MPAK	5
4196	MPAK	6
4197	MPAK	6
4260	CMPAK	6
4261	CMPAK	6
4262	CMPAK	6
4264	CMPAK	6
4265	CMPAK	6
4308	TO-92	6
4366	MPAK	5
4367	TO-92MOD	5
4463	CMPAK	6
4499	DPAK	9
4500	DPAK	9
4537	CMPAK	6
4591	MPAK	6
4593	CMPAK	6
4629	TO-92	6
4680	MPAK	6
4693	TO-92MOD	6
4702	MPAK	5
4784	CMPAK	6
4807	UPAK	6
4899	CMPAK	6
4901	CMPAK	6
4913	TO-220AB	9
4926	MPAK-4	6
4964	MPAK	6
4965	CMPAK	6
4988	UPAK	6
4995	CMPAK-4	6
5022	TO-220FM	9
5049	MPAK	6
5050	MPAK	6
5051	CMPAK	6
5080	MPAK-4	6
5081	CMPAK-4	6

■2SC series

Type No.	Package code	P
5137	SMPAK	6
5139	SMPAK	6
5218	MPAK	6
5247	SMPAK	6
5273	TO-220AB	9
5543	MFPK	6
5544	CMPAK	6
5545	MPAK-4	6
5554	MFPK	6
5555	MFPK	6
5593	CMPAK-4	6
5594	CMPAK-4	6
5623	CMPAK-4	6
5624	CMPAK-4	6
5628	MFPK	6
5629	SMPAK	6
5631	UPAK	6
5700	MFPK	6
5702	MFPK	6
5757	MFPK	6
5758	MFPK	6
5772	MPAK	6
5773	MPAK	6
5812	MFPK	6
5820	CMPAK-4	6
5850	CMPAK	5
5851	CMPAK	6
5894	CMPAK-4	6

■2SD series

Type No.	Package code	P
467	TO-92	5
468	TO-92MOD	5
476(K)	TO-220AB	9
476A(K)	TO-220AB	9
655	TO-92	5
667	TO-92MOD	5
667A	TO-92MOD	5
768(K)	TO-220AB	9
787	TO-92MOD	5
788	TO-92MOD	5
789	TO-92MOD	5
970(K)	TO-220AB	9
974	TO-92MOD	5
1101	MPAK	5
1113(K)	TO-220AB	9
1126(K)	TO-220AB	9
1133	TO-220AB	9
1134	TO-220AB	9
1135	TO-220AB	9
1137	TO-220AB	9
1138	TO-220AB	9
1163	TO-220AB	9
1163A	TO-220AB	9
1209(K)	TO-92MOD	5
1306	MPAK	5
1367	UPAK	6
1368	UPAK	6
1418	UPAK	6
1419	UPAK	6
1421	UPAK	6
1436(K)	TO-3P	9
1470	UPAK	6
1472	UPAK	6
1504	SPAK	5
1527	TO-220AB	9
1559	TO-3P	9
1606	TO-220AB	9
1922	TO-92MOD	5
1974	UPAK	6
1976	TO-220AB	9
1978	TO-92MOD	6
2101	TO-220FM	9
2104	TO-220FM	9
2106	TO-220FM	9
2107	TO-220FM	9
2115	DPAK	9
2121	DPAK	9
2122	DPAK	9
2123	DPAK	9
2124	DPAK	9
2213	TO-92MOD	6
2337	TO-220FM	9
2651	TO-92	5
2655	MPAK	5

■2SH series

Type No.	Package code	P
11	TO-220AB	13
12	TO-220AB	13
13	TO-220AB	13
14	TO-3P	13
15	TO-3P	13
16	TO-3PL	13

■2SH series

Type No.	Package code	P
17	TO-220AB	13
18	TO-220AB	13
19	TO-220AB	13
20	TO-3P	13
21	TO-3P	13
22	TO-3PL	13
26	TO-220AB	13
27	TO-220AB	13
28	TO-220AB	13
29	TO-220AB	13
30	TO-3P	13
31	TO-3P	13

■2SJ series

Type No.	Package code	P
76	TO-220AB	13
77	TO-220AB	13
78	TO-220AB	13
79	TO-220AB	13
130	DPAK	10
160	TO-3P	13
161	TO-3P	13
162	TO-3P	13
181	DPAK	10
186	UPAK	10
216	TO-3PFM	12
217	TO-3P	11
218	TO-3PFM	12
221	TO-220AB	10
222	TO-220FM	11
244	UPAK	10
247	TO-220AB	10
248	TO-220FM	11
278	UPAK	10
317	UPAK	10
319	DPAK	10
350	TO-220FM	11
351	TO-3P	13
352	TO-3P	13
361	UPAK	10
386	TO-92M	10
387	DPAK	10
399	MPAK	10
410	TO-220FM	11
451	MPAK	10
452	MPAK	10
471	TO-220CFM	11
479	LDPK	11
483	TO-92M	10
484	UPAK	10
486	MPAK	10
496	TO-92M	10
504	TO-220FM	11
505	LDPK	11
506	DPAK	10
517	UPAK	10
518	UPAK	10
526	TO-220FM	11
527	DPAK	10
528	DPAK	10
529	DPAK	10
530	DPAK	10
531	TO-220CFM	11
532	TO-220CFM	11
533	TO-220CFM	11
534	TO-220FM	11
535	TO-220FM	11
539	TO-220AB	10
540	TO-220AB	10
541	TO-220AB	10
542	TO-220AB	10
543	TO-220AB	10
544	TO-220AB	10
545	TO-220CFM	11
546	TO-220CFM	11
547	TO-220FM	11
548	TO-220FM	11
549	LDPK	11
550	LDPK	11
551	LDPK	11
552	LDPK	11
553	LDPK	11
554	TO-3P	11
555	TO-3P	11
574	MPAK	7
575	MPAK	7
576	CMPAK	7
586	CMPAK	7
587	SMPAK	7

■2SK series

Type No.	Package code	P
168	TO-92	7
213	TO-220AB	13

■2SK series

Type No.	Package code	P
214	TO-220AB	13
215	TO-220AB	13
216	TO-220AB	13
217	MPAK	7
359	TO-92	7
360	MPAK	7
435	TO-92	7
439	SPAK	7
494	SPAK	7
740	TO-220AB	10
975	TO-92M	10
1056	TO-3P	13
1057	TO-3P	13
1058	TO-3P	13
1070	MPAK	7
1151	DPAK	10
1152	DPAK	10
1153	TO-220AB	10
1154	TO-220AB	10
1155	TO-220AB	10
1156	TO-220AB	10
1157	TO-220AB	10
1158	TO-220AB	10
1159	TO-220AB	10
1160	TO-220AB	10

INDEX

■2SK series

Type No.	Package code	P
2788	UPAK	10
2796	DPAK	10
2800	TO-220AB	10
2802	MPAK	10
2828	TO-3P	11
2851	TO-92M	10
2869	DPAK	10
2885	LDPAK	11
2912	LDPAK	11
2925	DPAK	10
2926	DPAK	10
2927	TO-220AB	10
2928	TO-220AB	10
2929	TO-220AB	10
2930	TO-220AB	10
2931	TO-220AB	10
2932	TO-220CFM	11
2933	TO-220CFM	11
2934	TO-220CFM	11
2935	TO-220CFM	11
2936	TO-220CFM	11
2937	TO-220FM	11
2938	LDPAK	11
2939	LDPAK	11
2940	LDPAK	11
2955	TO-3P	11
2956	TO-220CFM	11
2957	LDPAK	11
2958	LDPAK	11
2959	TO-220AB	10
2978	UPAK	10
2980	MPAK	10
3000	MPAK	10
3069	TO-220AB	10
3070	LDPAK	11
3080	TO-220AB	10
3081	TO-220AB	10
3082	LDPAK	11
3134	LDPAK	11
3135	LDPAK	11
3136	TO-220AB	10
3140	TO-220CFM	11
3141	TO-220AB	10
3142	TO-220CFM	11
3147	DPAK	10
3148	TO-220FM	11
3149	TO-220AB	10
3150	LDPAK	11
3151	TO-3P	11
3152	TO-220FM	11
3153	TO-220FM	11
3154	TO-220AB	10
3155	TO-220FM	11
3156	TO-220AB	10
3157	TO-220FM	11
3158	TO-220AB	10
3159	TO-3P	11
3160	TO-220FM	11
3161	LDPAK	11
3162	TO-220FM	11
3163	TO-3P	11
3174A	RFPK-F	8
3175A	RFPK-G	8
3177	TO-220FM	11
3203	LDPAK	11
3209	TO-220FM	11
3210	LDPAK	11
3211	LDPAK	11
3212	TO-220FM	11
3214	TO-220AB	10
3215	TO-220AB	10
3228	TO-220AB	10
3229	TO-220CFM	11
3233	TO-220CFM	11
3234	TO-220CFM	11
3235	TO-3P	11
3274	DPAK	10
3287	MPAK	7
3288	MPAK	7
3289	CMPAK	7
3290	MPAK	7
3348	CMPAK	7
3349	SMPAK	7
3378	CMPAK	7
3390	RP8P	8
3391	UPAK	8
3418	TO-220AB	10
3419	TO-3P	11
3446	TO-92M	10
3447	TO-92M	10
3461	LDPAK	11
3464	RFPK-F	8

■2SK series

Type No.	Package code	P
3465	RFPK-G	8
3540	RFPK-F	8
3545	RFPK-F	8

■3SK series

Type No.	Package code	P
295	MPAK-4	7
296	CMPAK-4	7
297	MPAK-4	7
298	CMPAK-4	7
300	MPAK-4	7
309	CMPAK-4	7
317	CMPAK-4	7
318	CMPAK-4	7
319	MPAK-4	7

■4A series

Type No.	Package code	P
J11	SP-12	13
K15	SP-10	13
K16	SP-10	13
K17	SP-10	13
K18	SP-10	13
K19	SP-10	13
K20	SP-10	13
K21	SP-10	13
K23	SP-12TA	13
K25	SP-10	13
K26	SP-12	13
K27	SP-10	13
M11	SP-10	13
M12	SP-10	13
M13	SP-10	13
M14	SP-12TA	13
M15	SP-12TA	13
M16	SP-12	13

■6AM series

Type No.	Package code	P
11	SP-12	13
12	SP-12TA	13
13	SP-12TA	13
14	SP-12TA	13
15	SP-12TA	13

■BB FET series

Type No.	Package code	P
101C	CMPAK-4	7
101M	MPAK-4	7
102C	CMPAK-4	7
102M	MPAK-4	7
301C	CMPAK-4	7
301M	MPAK-4	7
302C	CMPAK-4	7
302M	MPAK-4	7
303C	CMPAK-4	7
303M	MPAK-4	7
304C	CMPAK-4	7
304M	MPAK-4	7
305C	CMPAK-4	7
305M	MPAK-4	7
501C	CMPAK-4	7
501M	MPAK-4	7
502C	CMPAK-4	7
502M	MPAK-4	7
503C	CMPAK-4	7
503M	MPAK-4	7
504C	CMPAK-4	7
504M	MPAK-4	7

■BICMIC series

Type No.	Package code	P
702C	CMPAK-4	7
702M	MPAK-4	7
703C	CMPAK-4	7
703M	MPAK-4	7

■GN series

Type No.	Package code	P
2550V4	LDPAK	13
6020V4	LDPAK	13
6030V4	LDPAK	13

■HA series

Type No.	Package code	P
22022	MPAK-5	8
22033	MPAK-5	8
22040	MPAK-6	8
22052	TNP-16BV	8

■HAF series

Type No.	Package code	P
1001	TO-220AB	13
1002	LDPAK	13
1004	DPAK	13
1009	LDPAK	13

■HAF series

Type No.	Package code	P
2001	TO-220AB	13
2002	TO-220FM	13
2005	TO-220FM	13
2007	DPAK	13
2008	TO-220FM	13
2011	LDPAK	13
2012	LDPAK	13
2015RJ	SOP-8	13
2017	LDPAK	13
2021	LDPAK	13

■HAT series

Type No.	Package code	P
1016R	FP-8DA	12
1020R	FP-8DA	12
1021R	FP-8DA	12
1023R	FP-8DA	12
1024R	FP-8DA	12
1025R	FP-8DA	12
1026R	FP-8DA	12
1029R	FP-8DA	12
1031T	TTP-8D	12
1033T	TTP-8D	12
1036R	FP-8DA	12
1038R/RJ	FP-8DA	12
1041T	TTP-8D	12
1043M	TSOP-6	12
1044M	TSOP-6	12
1048R	FP-8DA	12
1053M	TSOP-6	12
1054R	FP-8DA	12
1058C	CMFPAK-6	12
1059C	CMFPAK-6	12
1066G	CMPAK-6	7
1068C	CMFPAK-6	12
1069C	CMFPAK-6	12
1072H	LFPK	12
2016R	FP-8DA	12
2019R	FP-8DA	12
2020R	FP-8DA	12
2022R	FP-8DA	12
2024R	FP-8DA	12
2025R	FP-8DA	12
2026R	FP-8DA	12
2027R	FP-8DA	12
2028R/RJ	FP-8DA	12
2029R	FP-8DA	12
2031T	TTP-8D	12
2033R/RJ	FP-8DA	12
2036R	FP-8DA	12
2037T	TTP-8D	12
2038R/RJ	FP-8DA	12
2040R	FP-8DA	12
2042T	TTP-8D	12
2043R	FP-8DA	12
2044R	FP-8DA	12
2045T	TTP-8D	12
2050T	TTP-8D	12
2051T	TTP-8D	12
2052T	TTP-8D	12
2053M	TSOP-6	12
2054M	TSOP-6	12
2058R	FP-8DA	12
2064R	FP-8DA	12
2068R	FP-8DA	12
2070R	FP-8DA	12
2071R	FP-8DA	12
2077R	FP-8DA	12
2080R	FP-8DA	12
2080T	TTP-8D	12
2085T	TTP-8D	12
2085R	FP-8DA	12
2087R	FP-8DA	12
2088R	FP-8DA	12
2089R	FP-8DA	12
2092R	FP-8DA	12
2093R	FP-8DA	12
2095R	FP-8DA	12
2096H	LFPK	12
2099H	LFPK	12
2103R	FP-8DA	12
2106G	CMPAK-6	7
2108R	FP-8DA	12
2116H	LFPK	12
2119H	LFPK	12
2129H	LFPK	12
2134H	LFPK	12
2137H	LFPK	12
2139H	LFPK	12
2140H	LFPK	12
2141H	LFPK	12
2142H	LFPK	12
2143H	LFPK	12

■HAT series

Type No.	Package code	P
3004R	FP-8DA	12
3006R	FP-8DA	12
3008R/RJ	FP-8DA	12
3010R	FP-8DA	12
3016G	CMPAK-6	7

■H5N series

Type No.	Package code	P
0201MF	MFPK	7
0301MF	MFPK	7
0301SM	SMPAK	7
2004DL/DS	DPAK	10
2001LD/LS/LM	LDPAK	11
2003P	TO-3P	11
2005DL/DS	DPAK	10
2301PF	TO-3PFM	12
2503P	TO-3P	11
2504DL/DS	DPAK	10
2505DL/DS	DPAK	10
2507P	TO-3P	11
2508DL/DS	DPAK	10
2509P	TO-3P	11
2509PF	TO-3PFM	12
2510DL/DS	DPAK	10
3003P	TO-3P	11
3004P	TO-3P	11
3008P	TO-3P	12
5001FM	TO-220FM	11
5004PL	TO-3PL	12
5006DL/DS	DPAK	10
5006FM	TO-220FM	11
5006LD/LS/LM	LDPAK	11
5007P	TO-3P	12
5011PL	TO-3PL	12
6001P	TO-3P	12

■H5P series

Type No.	Package code	P
0201MF	MFPK	7
0301MF	MFPK	7
0301SM	SMPAK	7

■H7N series

Type No.	Package code	P
0201LD/LS/LM	LDPAK	11
0202LD/LS/LM	LDPAK	11
0203AB	TO-220AB	10
0307AB	TO-220AB	10
0307LD/LS/LM	LDPAK	11
0308AB	TO-220AB	10
0308CF	TO-220CFM	11
0308LD/LS/LM	LDPAK	11
0310LD/LS/LM	LDPAK	11
0311LD/LS/LM	LDPAK	11
0312AB	TO-220AB	10
0312LD/LS/LM	LDPAK	11
1004LD/LS	LDPAK	11
1005LD/LS	LDPAK	11

■PF series

Type No.	Package code	P
0414A	RF-K	14
0414B	RF-K-4	14
04140A	RF-K1	14
04111A	RF-K	14
04111B	RF-K-4	14
04112A	RF-K	14
04115B	RF-K2	14
08103A	RF-O	14
08103B	RF-O	14
08107B	RF-K-8	14
08107BP	RF-K-8	14
08109B	RF-K1-10	14
08122B	RF-K-8	14
08123B	RF-K-8	14

■TBB series

Type No.	Package code	P
1001	CMPAK-6	7

■TBB series

Type No.	Package code	P
1002	CMPAK-6	7
1004	CMPAK-6	7
1005	CMPAK-6	7

■BRT series

Type No.	Package code	P
BRA114	CMPAK	5
BRA114	MPAK	5
BRA114	ETP	5
BRA123	MPAK	5

SMALL SIGNAL TRANSISTOR

■ General Amplification

Package code	Type No.	Ratings		Characteristics		Status	
		V _{CEO} (V)	I _C (A)	hFE	V _{CE(sat)} (V) max		
SPAK	2SA1374	-55	-0.1	160~500	-0.5	○★	
	2SA1390	-35	-0.5	60~320	-0.6	○★	
	2SC3390	50	0.1	100~320	0.2	○★	
	2SC3413	30	0.1	100~500	0.2	○★	
	2SC3470	50	0.1	250~1200	0.2	※★	
	2SC3553	35	0.5	60~320	0.6	○★	
	2SC3836	50	0.3	800~2000	0.3	○★	
	2SD1504	15	0.5	250~1200	0.5	○★	
	TO-92	2SA673	-35	-0.5	60~320	-0.6	○★
		2SA673A	-50	-0.5	60~320	-0.6	○★
2SA836		-55	-0.1	160~500	-0.5	○★	
2SA844		-55	-0.1	160~500	-0.5	○★	
2SA872A		-120	-50 m	250~800	-0.5	○★	
2SA893		-90	-50 m	250~800	-0.5	※★	
2SA893A		-120	-50 m	250~800	-0.5	○★	
2SA1029		-30	-0.1	100~500	-0.2	○★	
2SA1030		-50	-0.1	100~320	-0.2	○★	
2SA1082		-120	-0.1	250~800	-0.2	※★	
2SA1084		-90	-0.1	250~800	-0.2	○★	
2SA1085		-120	-0.1	250~800	-0.2	○★	
2SA1188		-90	-0.1	250~800	-0.1	○★	
2SA1190		-90	-0.1	250~800	-0.1	○★	
2SA1191		-120	-0.1	250~800	-0.1	○★	
2SB561		-20	-0.7	85~240	-0.5	○★	
2SB1688		-300	-50 m	80~150	0.9	○★	
2SC458		30	0.1	100~500	0.2	○★	
2SC458LG		30	0.1	100~500	0.2	※★	
2SC1213		35	0.5	60~320	0.6	○★	
2SC1213A		50	0.5	60~320	0.6	○★	
2SC1214		50	0.5	60~320	0.6	○★	
2SC1344		30	0.1	250~1200	0.5	※★	
2SC1345		50	0.1	250~1200	0.5	○★	
2SC1775		90	50m	400~1200	0.5	○★	
2SC1775A		120	50 m	400~1200	0.5	○★	
2SC1890		90	50 m	250~1200	0.5	※★	
2SC1890A		120	50 m	250~1200	0.5	○★	
2SC2308		50	0.1	100~320	0.2	○★	
2SC2309		50	0.1	250~1200	0.2	○★	
2SC2310		50	0.1	100~320	0.2	※★	
2SC2396		60	0.1	250~1200	0.2	※★	
2SC2543		90	0.1	250~1200	0.2	※★	
2SC2544		120	0.1	250~800	0.2	※★	
2SC2545		60	0.1	250~1200	0.2	○★	
2SC2546		90	0.1	250~1200	0.2	○★	
2SC2547		120	0.1	250~800	0.2	○★	
2SC2853		90	0.1	250~800	0.1	○★	

		Ratings		Characteristics			
		V _{CEO} (V)	I _C (A)	hFE	V _{CE(sat)} (V) max		
TO-92	2SC2854	120	0.1	250~800	0.1	※★	
	2SC2855	90	0.1	250~800	0.1	※★	
	2SC2856	120	0.1	250~800	0.1	○★	
	2SD467	20	0.7	85~240	0.5	○★	
	2SD655	15	0.7	250~1200	0.5	○★	
	2SD2651	300	50 m	80~150	0.5	○★	
	2SB562	-20	-1.0	85~240	-0.5	○★	
	2SB647	-80	-1.0	60~320	-1.0	○★	
	2SB647A	-100	-1.0	60~200	-1.0	○★	
	2SB715	-100	-50 m	250~800	-0.2	※★	
TO-92	2SB716	-120	-50 m	250~800	-0.2	※★	
	2SB716A	-140	-50 m	250~500	-0.2	※★	
	2SB738	-16	-2.0	100~320	-0.3	※★	
	2SB739	-20	-2.0	100~320	-0.3	○★	
	2SB740	-50	-1.0	100~320	-0.6	○★	
	2SC1921	200	50 m	30~300	1.0	○★	
	2SC2610	300	0.1	30~200	1.5	○★	
	2SC4367	20	0.1	40~	1.0	○★	
	2SD468	20	1.0	85~240	0.5	○★	
	2SD667	80	1.0	60~320	1.0	○★	
	2SD667A	100	1.0	60~200	1.0	○★	
	2SD787	16	2.0	100~800	0.3	※★	
	2SD788	20	2.0	100~800	0.3	○★	
	2SD789	50	1.0	100~800	0.3	○★	
	2SD1922	25	0.8	250~1200	0.3	※★	
	MPAK	2SA1052	-30	-0.1	100~500	-0.2	○★
		2SA1121	-35	-0.5	60~320	-0.6	○★
		2SA1122	-55	-0.1	160~800	-0.5	○★
2SA1171		-90	-50 m	250~800	-0.5	○★	
2SA1484		-90	-0.1	250~800	-0.1	※★	
2SA1566		-120	-0.1	250~800	-0.1	○★	
2SA1617		-50	-0.1	100~320	-0.2	○★	
2SB831		-20	-0.7	85~240	-0.5	○★	
2SB1691		-50	-1	200~500	-0.3	○★	
2SC2462		40	0.1	100~500	0.2	○★	
2SC2463		50	0.1	250~1200	0.5	○★	
2SC2618		35	0.5	60~320	0.6	○★	
2SC4050		120	0.1	250~800	0.1	○★	
2SC4366		50	0.3	800~2000	0.3	※★	
2SC4702		300	50 m	60~150	0.5	○★	
2SD1101		20	0.7	85~240	0.5	※★	
2SD1306		15	0.7	250~800	0.5	○★	
2SD2655		50	1	200~500	0.3	○★	
CMPAK		2SA2080	-30	-100m	100~500	-0.2	○★
		2SA2081	-55	-100m	160~800	-0.5	○★
	2SC5850	40	100m	100~500	0.2	○★	

- 注) ○：正在批量生产
 SPL：样品正在发货
 △：可以批量生产（交货期为三个月）
 ※：限定品种
 ★：大量订货对象品种（订货单位为“500个的整数倍”）

■ BRT Series (Small Signal Switching)

Package code	Type No.	Ratings		Characteristics			Status	
		V _{CC} (V)	I _O (mA)	V _{I(on)} (V) max	G _i min	R ₁ (K Ω) typ		R _{1/R2} typ
TO-92	BRA114ETP	-50	-100	-2.4	30	10	1.0	※★
	BRA123ETP	-50	-100	-1.8	20	2.2	1.0	※★
	BRA124ETP	-50	-100	-3.0	56	22	1.0	※★
	BRA143ETP	-50	-100	-2.0	20	4.7	1.0	※★
	BRA144ETP	-50	-100	-4.5	70	47	1.0	※★
	BRC114ETP	50	100	2.4	30	10	1.0	※★
	BRC123ETP	50	100	1.8	20	2.2	1.0	※★
	BRC124ETP	50	100	3.0	56	22	1.0	※★
	BRC143ETP	50	100	2.0	20	4.7	1.0	※★
	BRC144ETP	50	100	4.5	70	47	1.0	※★
MPAK	BRA114EMP	-50	-100	-2.4	30	10	1.0	※★
	BRA123EMP	-50	-100	-1.8	20	2.2	1.0	※★
	BRA124EMP	-50	-100	-3.0	56	22	1.0	※★
	BRA143EMP	-50	-100	-2.0	20	4.7	1.0	※★
	BRA144EMP	-50	-100	-4.5	70	47	1.0	※★
	BRC114ECM	-50	-100	-2.4	30	10	1.0	※★

		Ratings		Characteristics				
		V _{CC} (V)	I _O (mA)	V _{I(on)} (V) max	G _i min	R ₁ (K Ω) typ		R _{1/R2} typ
MPAK	BRC114EMP	50	100	2.4	30	10	1.0	※★
	BRC123EMP	50	100	1.8	20	2.2	1.0	※★
	BRC124EMP	50	100	3.0	56	22	1.0	※★
	BRC143EMP	50	100	2.0	20	4.7	1.0	※★
	BRC144EMP	50	100	4.5	70	47	1.0	※★
CMPAK	BRA114ECM	-50	-100	-2.4	30	10	1.0	※★
	BRA123ECM	-50	-100	-1.8	20	2.2	1.0	※★
	BRA124ECM	-50	-100	-3.0	56	22	1.0	※★
	BRA143ECM	-50	-100	-2.0	20	4.7	1.0	※★
	BRA144ECM	-50	-100	-4.5	70	47	1.0	※★
	BRC114ECM	50	100	2.4	30	10	1.0	※★
	BRC123ECM	50	100	1.8	20	2.2	1.0	※★
	BRC124ECM	50	100	3.0	56	22	1.0	※★
BRC143ECM	50	100	2.0	20	4.7	1.0	※★	
BRC144ECM	50	100	4.5	70	47	1.0	※★	

SMALL SIGNAL TRANSISTOR

General Amplification

Package code	Type No.	Ratings		Characteristics		Status
		V _{CEO} (V)	I _C (A)	h _{FE}	V _{CE(sat)} (V) max	
UPAK	2SB1001	-16	-2.0	100~320	-0.3	○★
	2SB1002	-50	-1.0	100~320	-0.6	○★
	2SB1025	-80	-1.0	60~320	-1.0	○★
	2SB1026	-100	-1.0	60~200	-1.0	○★
	2SB1028	-160	-1.5	60~200	-1.0	○★
	2SC3380	300	0.1	30~200	1.5	○★

		Ratings		Characteristics		
		V _{CEO} (V)	I _C (A)	h _{FE}	V _{CE(sat)} (V) max	
UPAK	2SD1367	16	2.0	100~500	0.3	△★
	2SD1368	50	1.0	100~500	0.3	○★
	2SD1418	80	1.0	60~320	1.0	○★
	2SD1419	100	1.0	60~200	1.0	○★
	2SD1421	160	1.5	60~200	1.0	○★
	2SD1974	25	0.8	250~1200	0.4	△★

General Switching

Package code	Type No.	Ratings		Characteristics		Status
		V _{CEO} (V)	I _C (A)	h _{FE}	V _{CE(sat)} (V) max	
TO-92	2SA773A(K)	-50	-0.5	60~320	-0.6	○★
	2SA778(K)	-150	-50 m	30~	-1.0	※★
	2SA778A(K)	-180	-50 m	40~200	-1.0	○★
	2SC458(K)	30	0.1	100~500	0.4	○★
	2SC1213A(K)	50	0.5	60~320	0.6	○★

		Ratings		Characteristics		
		V _{CEO} (V)	I _C (A)	h _{FE}	V _{CE(sat)} (V) max	
TO-92	2SC1345(K)	50	0.1	250~1200	0.5	※★
	2SC1515(K)	150	50 m	30~300	1.0	○★
TO-92	2SD974	60	1.0	100~	0.3	○★

General Switching (Darlington transistor)

Package code	Type No.	Ratings		Characteristics		Status
		V _{CEO} (V)	I _C (A)	h _{FE}	toff (μs) typ	
TO-92	2SC1472(K)	30	0.3	2 k~100 k	0.8	○★
TO-92 MOD	2SA1193(K)	-60	-0.5	2 k~	0.9	○★
	2SD1209(K)	60	1.0	4 k~	—	○★
	2SD1978	120	1.5	2 k~30 k	2.0	○★
	2SD2213	80	1.5	5 k~30 k	4.0	○★

		Ratings		Characteristics		
		V _{CEO} (V)	I _C (A)	h _{FE}	toff (μs) typ	
MPAK-4	2SC3957	30	0.3	2 k~100 k	0.8	※★
UPAK	2SB1048	-60	-1.0	2 k~	0.9	○★
	2SD1470	60	1.0	2 k~100 k	—	○★
	2SD1472	120	1.5	2 k~30 k	2.0	○★

High Frequency Amplification

Package code	Type No.	Ratings		Characteristics			Status		
		V _{CEO} (V)	I _C (A)	f _r (GHz) typ	NF (dB) typ	Cob (pF) max			
SPAK	2SC3391	20	20 m	0.94	3.5	0.1	1.2	○★	
TO-92	2SC460	30	0.1	0.23	—	—	3.5	○★	
	2SC461	30	0.1	0.23	—	—	3.5	○★	
	2SC535	20	20 m	0.94	3.5	0.1	1.2	○★	
	2SC1906	19	50 m	1.0	—	—	2.0	○★	
	2SC1907	19	50 m	1.1	—	—	2.0	○★	
	2SC2471	30	50 m	2.0	—	—	1.5	※★	
	2SC2512	20	50 m	0.9	—	—	—	※★	
	2SC3128	12	50 m	4.5	2.2	0.9	1.5	※★	
	2SC3510	12	50 m	4.5	2.2	0.9	1.5	※★	
	2SC3512	11	50 m	6.0	1.6	0.9	1.6	※★	
	2SC4308	20	0.3	2.5	—	—	4.0 typ	○★	
	2SC4629	9.0	50 m	8.0	1.2	0.9	1.85	※★	
	TO-92 MOD	2SC4693	20	0.3	2.5	—	—	4.5 typ	※★
	MFPAK (1408)	2SC5543	8	20 m	8.5	1.1	0.9	0.9	○★
		2SC5544	8	50 m	6	1.0	0.9	1.4	○★
		2SC5554	9	20 m	7	1.4	0.9	0.9	○★
		2SC5555	8	50 m	9	1.1	0.9	0.85	○★
		2SC5628	6	50 m	5	1.1	0.9	1.3	○★
		2SC5700	4	50 m	16.0	0.9	0.9	0.8	○★
		2SC5702	6	50 m	7.8	1.1	0.9	0.9	○★
2SC5757		3.5	80 m	6.5	1.2	0.9	1.2	○★	
2SC5758		3.5	80 m	8	1.2	0.9	0.95	○★	
2SC5812		4	50 m	15	1	0.9	0.4	○★	
SMPAK		2SC5137	8.0	20 m	10	1.5	0.9	0.8	△★
		2SC5139	8.0	50 m	11	1.1	0.9	1.1	○★
		2SC5247	8	50 m	13.5	1.2	0.9	0.75	○★
CMPAK	2SC5629	6	50 m	5	1.1	0.9	1.3	○★	
	2SC4260	13	50 m	3.8	—	—	1.5	○★	
	2SC4261	15	50 m	2.4	—	—	1.0	○★	
	2SC4262	15	50 m	2.9	—	—	1.0	○★	
	2SC4264	11	50 m	3.5	—	—	1.5	○★	
	2SC4265	20	50 m	1.2	—	—	1.5	○★	
	2SC4463	20	50 m	1.0	—	—	—	※★	
	2SC4537	11	50 m	6.0	1.6	0.9	1.5	○★	
	2SC4593	9.0	50 m	9.0	1.2	0.9	1.5	※★	
	2SC4784	8.0	20 m	10	1.2	0.9	0.8	○★	
2SC4899	9.0	20 m	9.0	1.2	0.9	0.85	○★		

		Ratings		Characteristics				
		V _{CEO} (V)	I _C (A)	f _r (GHz)	NF (dB) typ	Cob (pF)		
CMPAK	2SC4901	9.0	50 m	9.0	1.2	0.9	1.4	○★
	2SC4965	8.0	100m	—	—	—	1.6	○★
	2SC5051	8.0	50 m	11	1.1	0.9	1.15	○★
	2SC5851	30	100m	0.23	5.5	0.1	1.6	○★
	2SC4995	8.0	50 m	11	1.1	0.9	1.05	○★
CMPAK-4	2SC5081	8.0	50 m	13.5	1.1	0.9	0.75	○★
	2SC5593	4	12 m	23	1.9	1.8	0.4	○★
	2SC5594	4	35 m	22	1.2	1.8	0.6	○★
	2SC5623	3.5	12 m	27	1.8	1.8	0.4	○★
	2SC5624	3.5	35 m	28	1.2	1.8	0.6	○★
	2SC5820	4.6	35	20	1.4	1.8	0.15	○★
	2SC5894	4.6	12	20	2	1.8	0.29	SPL★
	2SC2619	30	0.1	0.23	—	—	3.5	○★
	2SC2620	20	20 m	0.94	—	—	1.2	○★
	2SC2732	25	20 m	1.0	—	—	0.8	※★
MPAK	2SC2734	11	50 m	3.5	—	—	1.5	○★
	2SC2735	20	50 m	1.2	—	—	1.5	○★
	2SC2736	20	50 m	2.2	—	—	1.0	※★
	2SC2776	20	30 m	0.32	5.5	0.1	1.5	※★
	2SC3127	12	50 m	4.5	2.2	0.9	1.5	○★
	2SC3513	11	50 m	6.0	1.6	0.9	1.5	※★
	2SC3793	15	50 m	2.9	—	—	1.0	※★
	2SC4196	15	50 m	2.4	—	—	1.0	○★
	2SC4197	13	50 m	3.8	—	—	1.3	○★
	2SC4591	9.0	50 m	9.0	1.2	0.9	1.5	○★
	2SC4680	8.0	50 m	—	—	—	1.5	※★
	2SC4964	8.0	100m	—	—	—	1.6	※★
	2SC5049	8.0	20 m	10	1.2	0.9	0.8	○★
	2SC5050	8.0	50 m	11	1.1	0.9	1.1	○★
	2SC5218	9.0	50 m	9.0	1.2	0.9	1.4	○★
MPAK-4	2SC5772	9	100m	9	1.1	0.9	0.9	○★
	2SC5773	6	80 m	10.8	1.1	0.9	1.25	○★
	2SC4926	8.0	50 m	11	1.1	0.9	1.1	○★
	2SC5080	8.0	50 m	13.5	1.1	0.9	0.75	△★
	2SC5545	6.0	50 m	13	1.1	0.9	1.1	○★
UPAK	2SC4807	15	200m	4.4	2.5	0.9	2.8	○★
	2SC4988	9.0	100m	8.5	1.3	0.9	1.6	○★
	2SC5631	6.0	80 m	11	1.8	0.9	2.0	○★

Twin Transistors

Package code	Type No.	Ref. Chip Q1						Ref. Chip Q2						Status		
		Ratings		Characteristics		Cre (pF)	Ratings		Characteristics		Cre (pF)					
		V _{CEO} (V)	I _C (A)	f _r (GHz) typ	NF (dB) typ		f (GHz)	V _{CEO} (V)	I _C (A)	f _r (GHz) typ		NF (dB) typ	f (GHz)			
SMFPAK-6	HTT1115S	2SC5700	4	50 m	13	1.0	0.9	0.3	2SC5757	3.5	80 m	6	1.5	0.9	0.8	○★
	HTT1213S	2SC5700	4	50 m	12	1.0	0.9	0.3	2SC5700	4.0	50 m	12	1.0	0.9	0.3	○★
EMFPAK-6	HTT1115E	2SC5700	4	50 m	13	1.0	0.9	0.3	2SC5757	3.5	80 m	6	1.5	0.9	0.8	○★
	HTT1213E	2SC5700	4	50 m	12	1.0	0.9	0.3	2SC5700	4.0	50 m	12	1.0	0.9	0.9	○★

SMALL SIGNAL FET

High Frequency Amplification

Package code	Type No.	Ratings		Characteristics				Status
		V _{DS} (V)	I _D (A)	C _{iss} (pF) typ	PG(dB) typ	NF (dB) typ	f (GHz)	
SPAK	2SK439	20	30m	2.5	30	2.0	0.1	○★
TO-92	2SK168	30	20m	5.0	27	1.7	0.1	※★
	2SK359	20	30m	2.5	30	2.0	0.1	○★
CMPAK	2SK1215	20	30m	2.5	30	2.0	0.1	○★
CMPAK-4	2SK2685☆	6	20m	0.80	21	0.5	0.9	○★
	3SK296	12	25m	1.5	19.5	2.0	0.9	○★
	3SK298	12	25m	2.9	25	1.0	0.2	○★
	3SK309☆	6	18m	0.39	21	1.25	0.9	○★
	3SK317	14	25m	3.0	27.6	1.0	0.2	○★
	3SK318	6	20m	1.7	21.5	1.6	0.9	○★
	BB101C	6	25m	1.7	20	2.1	0.9	○★
	BB102C	12	25m	1.6	20	2.1	0.9	※★
	BB301C	6	25m	3.1	26	1.3	0.2	○★
	BB302C	12	25m	3.0	26	1.7	0.2	※★
	BB303C	7	25m	3.3	32	1.0	0.2	△★
	BB304C	12	25m	3.1	29	1.2	0.2	○★
	BB305C	12	25m	3.1	28	1.5	0.2	○★
	BB501C	6	20m	1.7	21.5	1.8	0.9	○★
	BB502C	6	20m	1.7	22	1.6	0.9	○★
	BB503C	6	20m	1.7	22	1.8	0.9	△★
	BB504C	6	30m	2.1	22	1.75	0.9	△★
	BIC702C	6	20m	2.0	23	1.6	0.9	※★
	BIC703C	6	30m	2.0	22	1.8	0.9	※★

		Ratings		Characteristics				
		V _{DS}	I _D	C _{iss}	PG(dB)	NF (dB)	f (GHz)	
MPAK	2SK217	30	20m	6.8	27	1.7	0.1	※★
	2SK360	20	30m	2.5	30	2.0	0.1	○★
MPAK-4	3SK295	12	25m	1.5	19.5	2.0	0.9	○★
	3SK297	12	25m	2.9	25	1.0	0.2	○★
	3SK300	14	25m	3.1	27.6	1.0	0.2	○★
	3SK319	6	20m	1.7	21.5	1.6	0.9	○★
	BB101M	6	25m	1.7	20	2.1	0.9	○★
	BB102M	12	25m	1.6	20	2.1	0.9	○★
	BB301M	6	25m	3.1	26	1.3	0.2	○★
	BB302M	12	25m	3.0	26	1.7	0.2	※★
	BB303M	7	25m	3.3	32	1.0	0.2	△★
	BB304M	12	25m	3.1	29	1.2	0.2	○★
	BB305M	12	25m	3.1	28	1.5	0.2	○★
	BB501M	6	20m	1.7	21.5	1.8	0.9	○★
	BB502M	6	20m	1.7	22	1.6	0.9	△★
BB503M	6	20m	1.7	22	1.8	0.9	△★	
BB504M	6	30m	2.1	22	1.75	0.9	△★	
BIC702M	6	20m	2.0	23	1.6	0.9	※★	
BIC703M	6	30m	2.0	22	1.8	0.9	※★	

High Frequency Amplification (Twin Type)

Package code	Type No.	Ratings		Characteristics (FET-1)				Characteristics (EET-2)				Status
		V _{DS} (V)	I _D (A)	C _{iss} (pF) typ	lyfsl (mS) typ	NF (dB) typ	f (GHz)	C _{iss} (pF) typ	lyfsl (mS) typ	NF (dB) typ	f (GHz)	
CMPAK-6	TBB1001	6	40m	3.5	42	1.2	0.2	3.5	42	1.2	0.2	△★
	TBB1002	6	30m	1.8	26	1.7	0.9	2.6	25	1.2	0.2	○★
	TBB1004	6	30m	1.8	26	1.7	0.9	2.7	32	1.2	0.2	○★
	TBB1005	6	30m	1.8	26	1.7	0.9	2.6	25	1.2	0.2	△★

μ-FET Series (Small signal switching)

Package code	Type No.	V _{DSS} (V)	I _D (A)	RDS(on) (Ω)								C _{iss}	Status
				VGS = 10V		VGS = 4V		VGS = 2.5V		VGS = 1.5V			
MPAK	2SJ574	-30	-0.3	1.1	1.3	2.2	3.1	—	—	—	—	50	○★
	2SJ575	-30	-0.1	2.8	3.3	5.7	7.9	—	—	—	—	25	△★
	2SK3287	30	0.3	1.26	1.44	2.8	3.44	—	—	—	—	6	○★
	2SK3288	30	0.1	2.7	3.5	4.7	7.0	—	—	—	—	3	○★
	2SK3290	30	0.5	0.46	0.525	0.9	1.25	—	—	—	—	5	○★
CMPAK	2SJ576	-30	-0.1	2.8	3.3	5.7	7.9	—	—	—	—	25	○★
	2SJ586	-20	-0.1	—	—	4.1	5.0	6.0	8.5	—	—	28	○★
	2SK3289	30	0.3	1.26	1.44	2.8	3.44	—	—	—	—	6	○★
	2SK3348	20	0.1	—	—	1.6	1.9	2.2	3.2	—	—	18	○★
	2SK3378	30	0.1	2.7	3.5	4.7	7.0	—	—	—	—	1.6	○★
SMPAK	2SJ587	-20	50m	—	—	8.5	11.0	15.0	22.0	—	—	13	○★

				RDS(on) (Ω)									
				VGS = 10V		VGS = 4V		VGS = 2.5V		VGS = 1.5V			
SMPAK	2SK3349	20	50m	—	—	2.8	3.6	4.8	7.2	—	—	6	○★
	H5N0301SM	30	50m	—	—	6	7.2	9	13	—	—	12	△★
MFPAK	H5P0301SM	-30	50m	—	—	16	20	22	30	—	—	15	△★
	H5N0201MF	20	0.05	—	—	2.8	3.6	4.8	7.2	—	—	6	△★
	H5N0301MF	30	0.05	—	—	6	7.2	9	13	—	—	12	△★
CMPAK-	H5P0201MF	-20	-0.05	—	—	8.5	11.0	15.0	22.0	—	—	13	△★
	H5P0301MF	-30	-0.05	—	—	16	20	22	30	—	—	15	△★
	HAT1066G	-30	-0.05	—	—	16	20	22	31	—	—	12	SPL
	HAT2106G	30	0.05	—	—	6.5	8	10	14	—	—	15	SPL
	HAT3016G	-30/30	-0.05/0.05	—	—	16/6.5	20/8	22/10	31/20	—	—	12/15	SPL

General Amplification

Package code	Type No.	Ratings		Characteristics		Status	
		V _{DS} (V _{DSX}) (V)	V _{GSS} (V _{GSS}) (V)	I _D (I _G) (A)	lyfsl (mS) min		I _{DSS} (mA)
SPAK	2SK494	22	—	0.1	20	6~40	○★
TO-92	2SK435	22	—	0.1	20	6~40	○★
MPAK	2SK1070	—	(-22)	50m	20	6~40	○★

注) ○: 正在批量生产
 SPL: 样品正在发货
 △: 可以批量生产 (交货期为三个月)
 ※: 限定品种
 ★: 大量订货对象品种 (订货单位为“500个的整数倍”)
 ☆: GaAs

GaAs LINEAR IC

■ High Frequency Linear IC

Package code	Type No.	Function & Characteristics	Status
MPAK-5	HA22022	LNA, $V_{DD} = 3\text{ V}$, $I_{DD} = 3\text{ mA typ}$, $NF = 1.3\text{ dB typ}$ (f = 1.5 GHz), $PG = 16\text{ dB typ}$ (f = 1.5 GHz)	○
	HA22033	LNA, $V_{DD} = 2.7\text{ V}$, $I_{DD} = 1.7\text{ mA typ}$, $NF = 1.4\text{ dB typ}$ (f = 1.5 GHz), $PG = 14\text{ dB typ}$ (f = 1.5 GHz)	○

Package code	Type No.	Function & Characteristics	Status
MPAK-6	HA22040	PDC MIXER, $CG = 10\text{ dB typ}$, $NF = 45\text{ dB typ}$ ($V_{CC} = 2.7\text{ V}$, $I_D = 6\text{ mA}$, f = 1.5 GHz)	○
TNP-16BV	HA22052	CDMA/LNA+MIXER, $V_{DD} = 2.8\text{ V}$, $I_{DD} = 20\text{ mA}$, f = 894 MHz	○

HIGH FREQUENCY POWER MOS FET

■ High Frequency Power Amplification

Package code	Type No.	Ratings		Characteristics				Status
		V_{DSS} (V)	I_D (A)	Pout (W) typ				
				f (MHz)	Pin (W)	V_{DD} (V)		
RFPK-F	2SK3174A	60	16	270	860	14	28	SPL
	2SK3464	60	14	180	1482	10	28	△
	2SK3540	60	20	390	860	24	28	△
	2SK3545	60	20	260	2140	20	28	SPL
RFPK-G	2SK3175A	60	8	135	860	7	28	SPL
	2SK3465	60	7	90	1482	5	28	△

		Ratings		Characteristics				
		V_{DSS}	I_D	Pout (dBm) min				
				f (MHz)	Pin (dBm)	V_{DD} (V)		
UPAK	2SK3391	17	0.3	32	836	14	13.7	○
RP8P	2SK3390	17	1	38	836	21	13.7	○

POWER TRANSISTOR

■ General Amplification

Package code	Type No.	Ratings		Characteristics		Status
		V _{CEO} (V)	I _C (A)	h _{FE}	V _{CE(sat)} (V) max	
DPAK	2SB1407(L)/(S)	-35	-2.5	60~320	-1.0	○
	2SB1409(L)/(S)	-160	-1.5	60~200	-1.0	○
	2SD2121(L)/(S)	35	2.5	60~320	1.0	○
	2SD2122(L)/(S)	120	1.5	60~200	1.0	※
	2SD2123(L)/(S)	160	1.5	60~200	1.0	○

		Ratings		Characteristics		
		V _{CEO} (V)	I _C (A)	h _{FE}	V _{CE(sat)} (V) max	
TO-220	2SB857	-50	-4.0	60~320	-1.0	○
	2SB858	-60	-4.0	60~320	-1.0	○
	2SB859	-80	-4.0	60~200	-2.0	○
	2SB860	-100	-4.0	50~250	-1.0	○
	2SB861	-150	-2.0	60~200	-3.0	○
	2SD1133	50	4.0	60~320	1.0	○
	2SD1134	60	4.0	60~320	1.0	○
	2SD1135	80	4.0	60~200	2.0	○

■ General Switching

Package code	Type No.	Ratings			Characteristics		Status
		V _{CEO} (V)	V _{CB0} (V _{CEs}) (V)	I _C (A)	V _{CE(sat)} (V) max	t _r (μs) max	
DPAK	2SC4499(L)/(S)	400	500	0.5	1.0	1.0	○
	2SD2115(L)/(S)	60	150	2.0	0.8	0.6	○
TO-220 AB	2SB566(K)	-50	-70	-40	-1.0	0.5 typ	○
	2SB566A(K)	-60	-70	-40	-1.0	0.5 typ	○
	2SC2612	400	500	3.0	1.0	1.0	○
	2SC2613	400	500	5.0	1.0	1.0	○
	2SC2816	400	500	5.0	1.0	0.5	○
	2SC2898	400	500	8.0	1.0	0.8	○
	2SC2979	800	900	3.0	1.0	0.8	○
	2SC4913	2000	2000	20 m	5.0	—	○
	2SC5273	1300	1300	0.03	5.0	—	○
	2SD476(K)	50	70	4.0	1.0	0.5 typ	○
	2SD476A(K)	60	70	4.0	1.0	0.5 typ	○

		Ratings			Characteristics		
		V _{CEO} (V)	V _{CB0} (V _{CEs}) (V)	I _C (A)	V _{CE(sat)} (V) max	t _r (μs) max	
TO-220	2SD1137	100	100	4.0	1.0	—	○
	2SD1138	150	200	2.0	3.0	—	○
	2SD1163	120	300	7.0	2.0	0.5	○
	2SD1163A	150	350	7.0	1.0	0.5	○
	2SD1527	1000	—	0.5	5.0	—	○
TO-220	2SB1392	-60	-70	-4.0	-1.0	—	○
	2SB1530	-150	-200	-2.0	-3.0	—	△
	2SC5022	1500	1500	20 m	5.0	—	○
	2SD2107	60	70	4.0	1.0	—	○
	2SD2337	150	200	2.0	3.0	—	○
TO-3P	2SC3336	400	500	15	1.0	0.5	○
	2SC3365	400	500	10	1.0	1.0	○

■ General Switching (Darlington transistor)

Package code	Type No.	Ratings		Characteristics		Status
		V _{CEO} (V)	I _C (A)	h _{FE}	t _{off} (μs) typ	
DPAK	2SC4500(L)/(S)	60	1.0	2 k~	0.6	○
	2SD2124(L)/(S)	120	1.5	2 k~30 k	2.0	○
TO-220 AB	2SB727(K)	-120	-6.0	1 k~20 k	3.0	○
	2SB791(K)	-120	-8.0	1 k~20 k	3.1	○
	2SB955(K)	-120	-10	1 k~20 k	4.0	○
	2SB1091	-60	-8.0	1 k~20 k	3.0	○
	2SB1103	-60	-8.0	1 k~20 k	4.0	○
	2SC1881(K)	60	3.0	1 k~	5.0	○
	2SD768(K)	120	6.0	1 k~20 k	3.0	○
	2SD970(K)	120	8.0	1 k~20 k	6.5	○
	2SD1113(K)	300	6.0	500~	23	○
	2SD1126(K)	120	10	1 k~20 k	8.0	○
	2SD1606	120	6.0	1 k~20 k	9.0	○
	2SD1976	300	6.0	500~	16.0	○

		Ratings		Characteristics			
		V _{CEO} (V)	I _C (A)	h _{FE}	t _{off} (μs) typ		
TO-220	2SB1389	-60	-4.0	1 k~20 k	5.0	○	
	2SB1390	-60	-8.0	1 k~20 k	4.0	○	
	2SB1391	-120	-8.0	1 k~20 k	3.1	○	
	2SB1399	-120	-10	1 k~20 k	4.0	○	
	2SB1400	-120	-6.0	1 k~20 k	3.0	○	
	2SD2101	200	10	1500~	11.5	○	
	2SD2104	120	8.0	1 k~20 k	6.5	○	
	2SD2106	120	6.0	1 k~20 k	3.0	○	
	TO-3P	2SB1032(K)	-120	-10	1 k~20 k	4.0	○
		2SB1079	-100	-20	1 k~20 k	3.5	○
2SB1494		-120	-25	2 k~20 k	10	○	
2SD1436(K)		120	10	1 k~20 k	4.0	○	
	2SD1559	100	20	1 k~20 k	12.0	○	

注) ○: 正在批量生产

SPL: 样品正在发货

△: 可以批量生产 (交货期为三个月)

※: 限定品种

★: 大量订货对象产品 (订货单位为“500个的整数倍”)

POWER MOS FET

General Switching

Package code	Type No.	Ratings		Characteristics			Ciss (pF) typ	Status
		Vdss (V)	Id (A)	Rds(ON) (Ω) max		Ciss (pF) typ		
				4 V (5 V)	10 V (2.5 V)			
TO-92	2SK1336	60	0.3	2.5	1.7	33	△★	
	2SK1337	100	0.3	6.5	4.5	35	△★	
TO-92 MOD	2SJ386	-30	-3.0	0.8	0.4	177	○★	
	2SJ483	-30	-5.0	0.17	0.11	630	△★	
	2SJ496	-60	-5	0.24	0.16	600	○★	
	2SK975	60	1.5	0.55	0.4	140	○★	
	2SK2085	100	1	1.35	0.9	130	△★	
	2SK2734	30	5	0.08	0.055	550	△★	
	2SK2851	60	5	0.1	0.07	500	○★	
	2SK3446	150	1	1.95	(2.5)	95	△★	
	2SK3447	150	1	2.5	1.95	85	△★	
	MPAK	2SJ399	-30	-0.2	5.0	3.0	1.1	○★
		2SJ451▼	-20	-0.2	3.5	(9)	2.4	○★
2SJ452▼		-50	-0.2	7.0	(12)	1.1	※★	
2SJ486▼		-30	-0.3	0.65	(1.2)	45	○★	
2SK2373		30	0.2	2.5	1.4	17.8	○★	
2SK2569▼		50	0.2	2.6	(5)	14	○★	
2SK2570▼		20	0.2	1.1	(2.2)	45	○★	
2SK2802▼		30	0.5	0.28	(0.5)	14	※★	
2SK2980▼		30	1.0	0.28	(0.5)	155	○★	
2SK3000		40	1	0.5	0.3	14	○★	
UPAK		2SJ186	-200	-0.5	—	12	75	○★
		2SJ244▼	-12	-2.0	0.5*	(0.9)	130	○★
		2SJ278	-60	-1.0	1.2	0.83	160	○★
		2SJ317▼	-12	-2.0	0.35	0.7 (-2.2V)	63	○★
		2SJ361▼	-20	-2.0	—	(1.5)	3.2	※★
	2SJ484	-30	-2.0	0.45	0.23	230	○★	
	2SJ517▼	-20	-2.0	0.24	(0.43)	320	○★	
	2SJ518	-60	-2.0	0.63	0.46	220	△★	
	2SK1334	200	1.0	—	3.8	80	○★	
	2SK1579▼	12	2.0	0.35	0.7 (2.2V)	110	○★	
	2SK1697	60	0.5	2.5	1.7	33	○★	
	2SK1698	100	0.3	6.5	4.5	35	※★	
	2SK1764	60	2.0	0.6	0.45	140	○★	
	2SK1772	30	1.0	0.85	0.6	30	○★	
	2SK2247	30	2.0	0.45	0.35	177	※★	
	2SK2315▼	60	2.0	0.45	0.6 (3V)	173	○★	
	2SK2788	60	2.0	0.25	0.16	180	○★	
	2SK2978▼	20	2.5	0.12	(0.2)	260	△★	
	DPAK	2SJ130(L)(S)	-300	-1.0	—	8.5	235	○
		2SJ181(L)(S)	-600	-0.5	—	25	220	○
2SJ319(L)(S)		-200	-3.0	—	2.3	330	○	
2SJ387(L)(S)▼		-20	-10	0.07	(0.11)	1170	○	
2SJ506(L)(S)		-30	-10	0.18	0.085	630	○	
2SJ527(L)(S)		-60	-5	0.8	0.4	220	○	
2SJ528(L)(S)		-60	-7	0.37	0.22	400	○	
2SJ529(L)(S)		-60	-10	0.24	0.16	580	○	
2SJ530(L)(S)		-60	-15	0.16	0.1	850	○	
2SK1151(L)(S)		450	1.5	—	5.5	160	○	
2SK1152(L)(S)		500	1.5	—	6	160	○	
2SK1254(L)(S)		120	3.0	0.55	0.4	420	○	
2SK1299(L)(S)		100	3.0	0.45	0.35	400	※	
2SK1335(L)(S)		200	3.0	—	0.8	380	※	
2SK1838(L)(S)		250	1.0	—	8	60	○	
2SK1880(L)(S)		600	1.5	—	8	250	○	
2SK2059(L)(S)		600	3.0	—	5	295	△	
2SK2084(L)(S)		20	7.0	0.075	0.053	800	○	
2SK2329(L)(S)▼		30	10	0.04	(0.06)	1250	○	
2SK2735(L)(S)		30	20	0.05	0.028	750	○	
2SK2796(L)(S)		60	5	0.25	0.16	180	○	
2SK2869(L)(S)		60	20	0.07	0.045	740	○	
2SK2925(L)(S)		60	10	0.16	0.08	350	○	
2SK2926(L)(S)		60	15	0.11	0.055	500	○	
2SK3147(L)(S)		100	5	0.17	0.13	420	○	

		Ratings		Characteristics			Ciss	
		Vdss	Id	Rds(ON) (Ω) max		Ciss		
				4 V (5 V)	10 V (2.5 V)			
DPAK	2SK3274(L)(S)	30	30	0.03	0.013	1500	○	
	H5N2004DL/DS	200	8	—	0.48	450	○	
	H5N2005DL/DS	200	6	—	0.65	300	○	
	H5N2504DL/DS	250	7	0.67	0.63	570	○	
	H5N2505DL/DS	250	5	—	0.89	300	○	
	H5N2508DL/DS	250	7	—	0.63	450	○	
	H5N2510DL/DS	250	5	0.97	0.89	390	○	
	H5N5006DL/DS	500	3	—	3.0	365	○	
	TO-220	2SJ221	-100	-20	0.22	0.16	1800	○
		2SJ247	-100	-8.0	0.45	0.3	880	○
2SJ539		-60	-10	0.36	0.21	400	○	
2SJ540		-60	-12	0.23	0.15	580	○	
2SJ541		-60	-15	0.155	0.095	850	○	
2SJ542		-60	-18	0.11	0.065	1300	○	
2SJ543		-60	-20	0.095	0.055	1750	○	
2SJ544		-60	-30	0.055	0.037	2500	○	
2SK740		150	10	—	1.5	1200	○	
2SK1153		450	3.0	—	2.8	330	○	
2SK1154		500	3.0	—	3	330	○	
2SK1155		450	5.0	—	1.4	640	○	
2SK1156		500	5.0	—	1.5	640	○	
2SK1157		450	7.0	—	0.8	1050	○	
2SK1158		500	7.0	—	0.9	1050	○	
2SK1159		450	8.0	—	0.7	1150	○	
2SK1160		500	8.0	—	0.8	1150	○	
2SK1300		100	10	0.35	0.25	525	○	
2SK1301		100	15	0.18	0.13	860	○	
2SK1302		100	20	0.12	0.085	1300	○	
2SK1338		900	2.0	—	7	425	○	
2SK1400		300	7.0	—	0.7	635	○	
2SK1400A		350	7.0	—	0.8	635	○	
2SK1402		600	4.0	—	2.4	600	○	
2SK1402A		650	4.0	—	2.6	600	○	
2SK1667		250	7.0	—	0.55	690	○	
2SK1761		250	12	—	0.35	1100	○	
2SK1807		900	4.0	—	4	740	○	
2SK1809		600	5.0	—	1.5	1000	○	
2SK2328		650	7.0	—	1.4	1180	○	
2SK2408▲	500	7	—	0.9	1100	○		
2SK2590	200	7	—	0.45	700	○		
2SK2800	60	40	0.04	0.02	1500	○		
2SK2927	60	10	0.15	0.075	350	○		
2SK2928	60	15	0.105	0.052	500	○		
2SK2929	60	25	0.07	0.034	740	○		
2SK2930	60	35	0.05	0.026	1100	△		
2SK2931	60	45	0.025	0.013	2200	○		
2SK2959	30	50	0.018	0.01	2000	○		
2SK3069	60	75	0.012	0.0075	7100	○		
2SK3080	30	30	0.05	0.028	750	△		
2SK3081	30	45	0.025	0.014	1570	○		
2SK3136	40	75	0.010	0.0058	6800	○		
2SK3141	30	75	0.0085	0.005	6800	○		
2SK3149	100	20	0.085	0.060	840	△		
2SK3154	150	15	0.15	0.13	850	○		
2SK3156	150	20	0.08	0.07	1750	○		
2SK3158	150	30	0.063	0.045	2600	△		
2SK3214	200	10	0.19	0.17	1100	△		
2SK3215	200	8	0.55	0.40	410	△		
2SK3228	80	75	0.012	0.0075	9800	○		
2SK3418	60	85	0.009	0.0055	9770	△		
H7N0203AB	20	90	0.0051	0.003	6800	○		
H7N0307AB	30	60	0.0115	0.0058	2500	△		
H7N0308AB	30	70	0.0085	0.0048	3350	△		
H7N0312AB	30	85	0.0058	0.0033	6900	△		

POWER MOS FET

General Switching

Package code	Type No.	Ratings		Characteristics			Status	
		VDSS (V)	ID (A)	RDS(ON) (Ω) max		Ciss (pF) typ		
				4 V (4.5 V)	10 V (2.5 V)			
TO-220 C-FM	2SJ471	-30	-30	0.06	0.035	1700	○	
	2SJ531	-60	-18	0.11	0.065	1300	○	
	2SJ532	-60	-20	0.095	0.055	1750	○	
	2SJ533	-60	-30	0.055	0.037	2500	○	
	2SJ545	-60	-12	0.23	0.15	580	○	
	2SJ546	-60	-15	0.155	0.095	850	○	
	2SK2114	450	5.0	—	1.4	640	○	
	2SK2116	450	7.0	—	0.8	1050	○	
	2SK2117	500	7.0	—	0.9	1050	○	
	2SK2118	600	5.0	—	1.5	1000	△	
	2SK2144	600	3.0	—	5	295	△	
	2SK2423	450	7	—	0.7	1150	※	
	2SK2425	250	7	—	0.55	690	○	
	2SK2426	250	12	—	0.35	1100	○	
	2SK2431	450	3.0	—	2.8	330	○	
	2SK2529	60	50	0.016	0.01	3550	○	
	2SK2725	500	5	—	1.6	630	○	
	2SK2726	500	7	—	0.95	1100	○	
	2SK2736	30	30	0.05	0.028	750	○	
	2SK2737	30	45	0.025	0.014	1570	○	
	2SK2738	60	40	0.04	0.02	1500	○	
	2SK2932	60	10	0.15	0.075	350	○	
	2SK2933	60	15	0.105	0.052	500	○	
	2SK2934	60	25	0.07	0.034	740	○	
	2SK2935	60	35	0.05	0.026	1100	○	
	2SK2936	60	45	0.025	0.013	2200	○	
	2SK2956	30	50	0.018	0.01	2000	○	
	2SK3140	60	60	0.012	0.0075	7100	○	
	2SK3142	30	60	0.0085	0.005	6800	○	
	2SK3229	80	60	0.012	0.0075	9800	○	
	2SK3233	500	5	—	1.5	580	○	
	2SK3234	500	8	—	0.85	970	○	
	H7N0308CF	30	60	0.0085	0.0048	3350	○	
	TO-220 FM	2SJ222	-100	-20	0.22	0.16	1800	○
		2SJ248	-100	-8.0	0.45	0.3	880	○
		2SJ350	-120	-6.0	0.9	0.7	900	○
		2SJ410	-200	-6	—	0.85	920	△
		2SJ504	-60	-20	0.095	0.055	1750	○
		2SJ526	-60	-12	0.23	0.15	580	○
		2SJ534	-60	-18	0.11	0.065	1300	○
2SJ535		-60	-30	0.055	0.037	2500	○	
2SJ547		-60	-10	0.36	0.21	400	○	
2SJ548		-60	-15	0.155	0.095	850	○	
2SK1305		100	10	0.35	0.25	525	○	
2SK1306		100	15	0.18	0.13	860	○	
2SK1307		100	20	0.12	0.085	1300	○	
2SK1318		120	20	0.16	0.12	1300	○	
2SK1404		600	5.0	—	1.5	1000	○	
2SK1566		450	7.0	—	0.8	1050	○	
2SK1567		500	7.0	—	0.9	1050	○	
2SK1572		600	3.0	—	5	295	○	
2SK1626		450	5.0	—	1.4	640	○	
2SK1627		500	5.0	—	1.5	640	○	
2SK1637		600	4.0	—	2.4	600	○	
2SK1668		250	7.0	—	0.55	690	○	
2SK1762		250	12	—	0.35	1100	○	
2SK1808		900	4.0	—	4	740	○	
2SK1862		450	3.0	—	2.8	330	○	
2SK1863		500	3.0	—	3	330	○	
2SK1957		200	7.0	—	0.45	700	○	
2SK2202		120	7.0	0.55	0.4	420	○	
2SK2212		200	10	—	0.3	1000	○	
2SK2422		650	4.0	—	2.6	600	△	
2SK2937		60	25	0.07	0.034	740	○	
2SK3148		100	20	0.085	0.060	840	○	
2SK3152		120	10	0.17	0.13	580	○	
2SK3153		120	15	0.11	0.085	830	△	
2SK3155		150	15	0.15	0.13	850	○	
2SK3157		150	20	0.08	0.07	1750	○	
2SK3160		200	10	0.19	0.17	1100	○	
2SK3162		200	20	0.085	0.075	2420	○	
2SK3177		200	15	0.125	0.115	1550	○	
2SK3209		150	25	0.063	0.045	2600	○	
2SK3212	100	5	0.17	0.13	420	△		
H5N5001FM	500	5	—	1.5	580	○		
H5N5006FM	500	3	—	3.0	365	○		
LDBPAK	2SJ479(L)/(S)	-30	-30	0.06	0.035	1700	○	
	2SJ505(L)/(S)	-60	-50	0.036	0.022	4100	○	
	2SJ549(L)/(S)	-60	-12	0.23	0.15	580	○	
	2SJ550(L)/(S)	-60	-15	0.155	0.095	850	○	
	2SJ551(L)/(S)	-60	-18	0.11	0.065	1300	○	
	2SJ552(L)/(S)	-60	-20	0.095	0.055	1750	○	
	2SJ553(L)/(S)	-60	-30	0.055	0.037	2500	○	
	2SK1313(L)/(S)	450	5.0	—	1.4	640	○	
	2SK1314(L)/(S)	500	5.0	—	1.5	640	○	
	2SK1315(L)/(S)	450	8.0	—	0.7	1150	○	
	2SK1316(L)/(S)	500	8.0	—	0.8	1150	○	
	2SK1528(L)/(S)	900	4.0	—	4	740	○	
	2SK1540(L)/(S)	450	7.0	—	0.8	1050	○	
	2SK1620(L)/(S)	150	10	—	0.15	1200	○	
	2SK1623(L)/(S)	100	20	0.12	0.085	1300	○	

		Ratings		Characteristics				
		VDSS	ID	RDS(ON) (Ω) max		Ciss		
				4 V (4.5 V)	10 V (2.5 V)			
LDBPAK	2SK1636(L)/(S)	250	15	—	0.27	1250	○	
	2SK1647(L)/(S)	900	2.0	—	7	425	○	
	2SK2553(L)/(S)	60	50	0.016	0.01	3550	○	
	2SK2684(L)/(S)	30	30	0.05	0.028	750	○	
	2SK2885(L)/(S)	30	45	0.025	0.014	1570	○	
	2SK2912(L)/(S)	60	40	0.04	0.02	1500	○	
	2SK2938(L)/(S)	60	25	0.07	0.034	740	○	
	2SK2939(L)/(S)	60	35	0.05	0.026	1100	○	
	2SK2940(L)/(S)	60	45	0.025	0.013	2200	○	
	2SK2957(L)/(S)	30	50	0.018	0.01	2000	○	
	2SK2958(L)/(S)	30	75	0.014	0.007	4100	○	
	2SK3070(L)/(S)	40	75	0.010	0.0058	6800	○	
	2SK3082(L)/(S)	60	10	0.15	0.075	350	○	
	2SK3134(L)/(S)	30	75	0.0085	0.005	6800	○	
	2SK3135(L)/(S)	60	75	0.012	0.0075	7100	○	
	2SK3150(L)/(S)	100	20	0.085	0.060	840	○	
	2SK3161(L)/(S)	200	15	0.125	0.115	1550	○	
	2SK3203(L)/(S)	30	45	0.028	0.014	1200	○	
	2SK3210(L)/(S)	150	30	0.063	0.045	2600	○	
	2SK3211(L)/(S)	200	25	0.085	0.075	2420	○	
	2SK3461(L)/(S)	60	85	0.009	0.0055	9770	○	
	H5N2901LD/LS/LM	200	20	—	0.125	1350	△	
	H5N5006LD/LS/LM	500	3.5	—	3.0	365	△	
	H7N0201LD/LS/LM	20	60	0.011	0.0048	2500	SPL	
	H7N0202LD/LS/LM	20	45	0.0155	0.0075	1650	SPL	
	H7N0307LD/LS/LM	30	60	0.0115	0.0058	2500	○	
	H7N0308LD/LS/LM	30	70	0.0085	0.0048	3350	△	
	H7N0310LD/LS/LM	30	30	(0.019)	0.01	1400	△	
	H7N0311LD/LS/LM	30	45	(0.016)	0.0088	1650	△	
	H7N0312LD/LS/LM	30	85	0.0058	0.0033	6900	△	
	H7N1004LD/LS	100	30	(0.045)	0.035	2800	SPL	
	H7N1005LD/LS	100	15	(0.155)	0.11	830	SPL	
	TO-3P	2SJ217	-60	-45	0.06	0.042	3800	○
		2SJ554	-60	-45	0.055	0.037	2500	○
		2SJ555	-60	-60	0.036	0.022	4100	○
		2SK1161	450	10	—	0.8	1050	○
		2SK1162	500	10	—	0.9	1050	○
		2SK1163	450	11	—	0.7	1150	○
		2SK1164	500	11	—	0.8	1150	○
		2SK1165	450	12	—	0.55	1450	○
2SK1166		500	12	—	0.6	1450	○	
2SK1167		450	15	—	0.36	2050	○	
2SK1168		500	15	—	0.4	2050	○	
2SK1169		450	20	—	0.25	2800	○	
2SK1170		500	20	—	0.27	2800	○	
2SK1303		100	30	0.09	0.06	1750	○	
2SK1304		100	40	0.04	0.03	3500	○	
2SK1317		1500	2.5	—	12	990	○	
2SK1339		900	3.0	—	7	410	○	
2SK1340		900	5.0	—	4	760	○	
2SK1341		900	6.0	—	3	980	○	
2SK1342		900	8.0	—	1.6	1730	○	
2SK1401		300	15	—	0.35	1250	○	
2SK1401A		350	15	—	0.4	1250	○	
2SK1403		600	8.0	—	1.3	1180	○	
2SK1403A		650	8.0	—	1.4	1180	○	
2SK1515▲		450	10	—	0.8	1050	○	
2SK1516▲		500	10	—	0.9	1050	○	
2SK1517▲		450	20	—	0.25	2800	○	
2SK1518▲		500	20	—	0.27	2800	○	
2SK1573		600	15	—	0.5	3150	○	
2SK1669▲		250	30	—	0.095	3100	○	
2SK1671		250	30	—	0.095	3100	○	
2SK1773		1000	5.0	—	2	1700	○	
2SK1835		1500	4.0	—	7	1700	○	
2SK1933		900	10	—	1.2	2620	○	
2SK1934		1000	8.0	—	1.6	2690	○	
2SK1968		600	12	—	0.88	1800	○	
2SK2007▲		250	20	—	0.15	2350	○	
2SK2075		250	20	—	0.13	2400	△	
2SK2096		60	45	0.028	0.022	3780	○	
2SK2554		60	75	0.01	0.006	7700	○	
2SK2568	500	12	—	0.6	1560	○		
2SK2586	60	60	0.016	0.01	3550	○		
2SK2727	500	10	—	0.95	1100	○		
2SK2728	500	18	—	0.45	2150	○		
2SK2729	500	20	—	0.29	3300	○		
2SK2730	500	25	—	0.24	3500	○		
2SK2828	700	12	—	1.2	1850	○		
2SK2955	60	45	0.025	0.013	2200	○		
2SK3151	100	50	0.025	0.015	4000	○		
2SK3159	150	50	0.042	0.030	4060	△		
2SK3163	60	75	0.012	0.0075	7100	○		
2SK3235	500	15	—	0.4	1920	○		
2SK3419	60	90	0.009	0.0055	9770	○		
H5N2003P	200	60	—	0.042	5150	△		
H5N2503P	250	50	—	0.055	5150	○		
H5N2507P▲	250	50	—	0.055	5000	△		
H5N2509P	250	30	—	0.069	3600	○		
H5N3003P	300	40	—	0.069	5150	○		
H5N3004P	300	25	—	0.093	3600	○		

POWER MOS FET

General Switching

Package code	Type No.	Ratings		Characteristics			Status	
		V _{DSS} (V)	I _D (A)	R _{DS(ON)} (Ω) max		C _{iss} (pF) typ		
				4 V (4.5 V)	10 V (2.5 V)			
TO-3P	H5N3008P▲	300	40	—	0.069	5150	△	
	H5N5007P	500	25	—	0.225	3900	○	
	H5N6001P	600	20	—	0.38	4640	○	
TO-3P FM	2SJ216	-60	-35	0.09	0.06	2400	○	
	2SJ218	-60	-45	0.06	0.042	3800	○	
	2SK1298	60	40	0.025	0.018	3600	○	
	2SK1328	450	12	—	0.55	1450	○	
	2SK1329	500	12	—	0.6	1450	○	
	2SK1405▲	600	15	—	0.5	2660	○	
	2SK1666	60	45	0.035	0.02	3950	△	
	2SK1670▲	250	30	—	0.095	3100	○	
	2SK1775	900	8.0	—	1.6	1730	○	
	2SK1832	500	10	—	0.9	1050	○	
	2SK1859	900	6.0	—	3	980	○	
	2SK2008▲	250	20	—	0.15	2350	○	
	2SK2203	60	50	0.013	0.01	8330	○	
	2SK2225	1500	2.0	—	12	990	○	
	H5N2301PF	230	25	—	0.085	2300	○	
	H5N2509PF	250	30	—	0.069	3600	△	
	TO-3PL	2SK1519▲	450	30	—	0.15	5800	○
		2SK1520▲	500	30	—	0.16	5800	○
		2SK1521▲	450	50	—	0.1	8700	○
		2SK1522▲	500	50	—	0.11	8700	○
		2SK1526	450	40	—	0.15	5800	○
		2SK1527	500	40	—	0.16	5800	○
		2SK1628	450	30	—	0.25	2800	○
		2SK1629	500	30	—	0.27	2800	○
		2SK1836	450	50	—	0.1	8150	○
2SK1837		500	50	—	0.11	8150	○	
2SK1947▲		250	50	—	0.06	5810	○	
2SK1948		250	50	—	0.06	5830	○	
2SK1971		500	35	—	0.23	8800	○	
2SK2393		1500	8	—	2.8	4370	○	
H5N5004PL▲		500	50	—	0.11	7630	△	
H5N5011PL		500	50	—	0.115	7700	△	
FP-8DA (JEDEC SOP-8)		HAT1016R(D)	-30	-4.5	0.18	0.09	660	○
		HAT1020R	-30	-5	0.13	0.07	860	○
	HAT1021R▼	-20	-5.5	0.06	(0.085)	1200	○	
	HAT1023R▼	-20	-7	0.04	(0.06)	2250	○	
	HAT1024R(D)	-30	-3.5	0.34	0.16	350	○	
	HAT1025R▼(D)	-20	-4.5	0.095	(0.15)	860	○	
	HAT1026R	-30	-7	0.065	0.037	1700	○	
	HAT1029R▼(D)	-20	-3.5	0.14	(0.23)	465	△	
	HAT1036R	-30	-12	0.034	0.014	4200	○	
	HAT1038R/RJ(D)	-60	-3.5	0.23	0.15	600	○	
	HAT1048R	-30	-16	(0.0135)	0.007	5700	○	
	HAT1054R▼(D)	-20	-6	(0.03)	(0.05)	1550	○	
	HAT2016R(D)	30	6.5	0.08	0.045	560	○	
	HAT2019R▼	30	8	0.027	(0.037)	920	※	
	HAT2020R	30	8	0.05	0.028	780	※	
	HAT2022R	30	11	0.025	0.015	1450	○	
	HAT2024R(D)	30	5.5	0.11	0.065	310	○	
	HAT2025R	30	8	(0.05)	0.026	660	○	
	HAT2026R▼	20	11	0.015	(0.021)	1760	○	
	HAT2027R▼(D)	20	7	0.038	(0.053)	720	○	
	HAT2028R/RJ(D)	60	4	0.16	0.10	280	○	
	HAT2029R▼(D)	28	7.5	0.033	(0.043)	780	○	
	HAT2033R/RJ	60	7	0.053	0.038	740	○	
	HAT2036R	30	12	(0.03)	0.015	1200	○	
	HAT2038R/RJ(D)	60	5	0.058	0.084	520	○	
	HAT2040R	30	15	0.013	0.008	4400	○	
	HAT2043R(D)	30	8	0.029	0.022	1170	○	
	HAT2044R▼	30	15	(0.009)	(0.013)	3420	△	
	HAT2058R(D)	100	4	0.18	0.145	420	○	
	HAT2064R	30	16	(0.01)	0.0063	2200	○	
	HAT2068R	30	14	(0.016)	0.009	1650	○	
	HAT2070R	30	12	(0.022)	0.014	1400	○	
	HAT2071R	30	10	(0.036)	0.020	740	○	
	HAT2077R	200	3	—	0.235	830	○	
	HAT2080R	250	1.7	—	0.85	300	○	
	HAT2085R	200	2	—	0.64	300	○	
	HAT2087R	250	2.5	—	0.31	830	○	
	HAT2088R	200	2	—	0.44	450	○	

		Ratings		Characteristics				
		V _{DSS}	I _D	R _{DS(ON)} (Ω) max		C _{iss}		
				4 V (4.5 V)	10 V (2.5 V)			
FP-8DA	HAT2089R	250	2	—	0.6	450	○	
	HAT2092R(D)	30	11	(0.025)	0.016	1400	△	
	HAT2093R(D)	30	9	(0.039)	0.023	750	○	
	HAT2095R	150	2.5	—	0.42	300	SPL	
	HAT2103R(D)	30	4.5	(0.13)	0.065	220	○	
	HAT2108R(D)	28	11	0.015	(0.022)	2200	○	
	HAT3004R (Nch/Pch)	30/-3	5.5/ -3.5	0.11/ 0.34	0.065/ 0.16	310/ 350	○	
	HAT3006R (Nch/Pch)	30/-3	6.5/ -4.5	0.08/ 0.18	0.045/ 0.09	560/ 660	○	
	HAT3008R/RJ (Nch/Pch)	60/-6	5/ -3.5	0.084/ 0.23	0.058/ 0.15	520/ 600	○	
	HAT3010R (Nch/Pch)	60	6/ -5	0.045/ 0.13	0.032/ 0.076	1050/ 1350	○	
	TTP-8D (TSSOP-8)	HAT1031T▼(D)	-20	-2.5	0.16	(0.28)	390	○
		HAT1033T▼	-20	-3.5	0.063	(0.09)	970	○
		HAT1041T▼	-20	-6	0.026	(0.045)	1850	○
		HAT2031T▼(D)	20	3.5	0.07	(0.098)	300	△
		HAT2037T▼	28	5.5	0.028	(0.038)	780	○
HAT2042T▼(D)		28	5	0.034	(0.044)	510	○	
HAT2045T▼(D)		28	6	0.026	(0.037)	650	○	
HAT2050T(D)		100	1	1	0.75	90	○	
HAT2051T▼(D)		30	1	0.2	(0.3)	155	○	
HAT2052T▼(D)		28	5	0.034	(0.044)	510	○	
TSOP-6	HAT2080T	250	1.2	—	0.85	300	○	
	HAT2085T	200	1.4	—	0.64	300	○	
	HAT1043M▼	-20	-4.4	(0.065)	(0.110)	750	○	
	HAT1044M	-30	-4.5	(0.105)	0.060	600	○	
	HAT1053M▼	-20	-5.5	(0.048)	(0.074)	1240	※	
	HAT2053M▼	20	6.1	(0.033)	(0.048)	570	○	
LFPACK	HAT2054M	30	6.3	(0.052)	0.031	620	○	
	HAT1072H	-30	-40	(0.0077)	0.0045	9100	○	
	HAT2096H	30	40	(0.0088)	0.0053	2200	○	
	HAT2099H	30	50	(0.0073)	0.0037	4750	○	
	HAT2116H	30	35	(0.015)	0.0077	1650	○	
	HAT2119H	250	5	—	0.63	450	○	
	HAT2129H	40	30	—	7.5	3300	△	
	HAT2134H	20	60	5.8	2.9	4500	△	
	HAT2137H	40	45	—	4.8	6200	△	
	HAT2139H	40	20	—	11.5	2000	△	
CMFPAK-6	HAT2140H	100	25	—	16	6350	△	
	HAT2141H	100	15	—	27.5	3200	△	
	HAT2142H	100	10	—	44	2000	△	
	HAT2143H	30	40	11.5	6.1	2450	○	
	HAT1058C▼	-20	-3	(0.074)	(0.126)	770	○	
	HAT1059C▼	-12	-3	(0.064)	(0.088)	500	○	
	HAT1068C▼	-20	-3	(0.065)	(0.096)	1010	SPL	
	HAT1069C▼	-12	-3	(0.059)	(0.077)	1310	SPL	

- 注) ○: 正在批量生产
 SPL: 样品正在发货
 △: 可以批量生产 (交货期为三个月)
 ※: 限定品种
 ★: 大量订货对象品种 (订货单位为“500个的整数倍”)
 ▼: 2.5 V R_{DS(ON)} (Ω)
 ▲: 高速二极管内藏品
 (D): 有双芯片
 HAT系列的样品, 正在以 HATxxxxWS 型号发货。

POWER MOS FET

■ General Amplification

Package code	Type No.	Ratings		Characteristics			Status
		V _{DSS} (V _{DSSX}) (V)	I _D (A)	lyfsl (S) typ	V _{DS(sat)} (V _{DS(on)}) (V) max	Ciss (pF) typ	
TO-220 AB	2SJ76	(-140)	-0.5	0.035	-2	120	○
	2SJ77	(-160)	-0.5	0.035	-2	120	○
	2SJ78	(-180)	-0.5	0.035	-2	120	○
	2SJ79	(-200)	-0.5	0.035	-2	120	○
	2SK213	(140)	0.5	0.04	2	90	○
	2SK214	(160)	0.5	0.04	2	90	○
	2SK215	(180)	0.5	0.04	2	90	○
	2SK216	(200)	0.5	0.04	2	90	○
TO-3P	2SJ160	(-120)	-7	1.0	-12	900	○

	Type No.	Ratings		Characteristics			Status
		V _{DSS} (V _{DSSX}) (V)	I _D (A)	lyfsl (S) typ	V _{DS(sat)} (V _{DS(on)}) (V) max	Ciss (pF) typ	
TO-3P	2SJ161	(-140)	-7	1.0	-12	900	○
	2SJ162	(-160)	-7	1.0	-12	900	○
	2SJ351	(-180)	-8	1.0	-12	800	○
	2SJ352	(-200)	-8	1.0	-12	800	○
	2SK1056	(120)	7	1.0	12	600	○
	2SK1057	(140)	7	1.0	12	600	○
	2SK1058	(160)	7	1.0	12	600	○
	2SK2220	(180)	8	1.0	12	600	○
	2SK2221	(200)	8	1.0	12	600	○

■ Array

Package code	Type No.	Ratings		Characteristics			Status	
		V _{DSS} (V)	I _D (A)	R _{DS(ON)} (Ω) max		Ciss (pF) typ		
				4 V	10 V (2.5 V)			
SP-10	4AK15	60	8.0	0.095	0.07	860	○	
	4AK16	60	5.0	0.25	0.18	400	○	
	4AK17	60	10	0.065	0.045	1400	○	
	4AK18	60	2.5	0.53	0.38	240	○	
	4AK19	120	5.0	0.6	0.5	—	○	
	4AK20	100	5.0	0.35	0.25	525	○	
	4AK21	100	8.0	0.125	0.09	1300	○	
	4AK25	60	1.5	0.6	0.45	140	○	
	4AK27	60	5	0.2	0.15	390	※	
	4AM11 (Nch/Pch)	60/ -60	5.0/ -5.0	0.24/ 0.27	0.17/ 0.2	400/ 900	○	
	4AM12 (Nch/Pch)	60/ -60	8.0/ -8.0	0.11/ 0.18	0.075/ 0.09	860/ 1400	○	
	4AM13 (Nch/Pch)	60/ -60	3.0/ -3.0	0.5/ 0.55	0.35/ 0.4	240/ 425	○	
	SP-12	4AJ11	-60	8.0	0.17	0.13	1400	○
		4AK26	60	8.0	0.075	0.06	1400	○

	Type No.	Ratings		Characteristics			Status
				R _{DS(ON)} (Ω) max			
				4 V	10 V (2.5 V)		
SP-12	4AM16 (Nch/Pch)	60/ -60	8.0/ -8.0	0.24/ 0.27	0.17/ 0.2	400/ 850	※
	6AM11 (Nch/Pch)	60/ -60	5.0/ -5.0	0.24/ 0.27	0.17/ 0.2	400/ 900	○
SP-12T	4AK23	100	5.0	0.25	0.25	400	※
	4AM14 (Nch/Pch)	60/ -60	8.0/ -8.0	0.24/ 0.27	0.17/ 0.2	400/ 900	○
	4AM15 (Nch/Pch)	200/ -200	4.0/ -4.0	—	0.5/ 0.7	600/ 800	○
	6AM12 (Nch/Pch)	60/ -60	7.0/ -7.0	0.24/ 0.27	0.17/ 0.2	400/ 900	○
	6AM13 (Nch/Pch)	60/ -60	10/ -10	0.11/ 0.18	0.075/ 0.12	860/ 1400	○
	6AM14 (Nch/Pch)	60/ -60	7.0/ -7.0	0.2/ 0.16	(0.5)/ (0.3)	500/ 1450	○
	6AM15 (Nch/Pch)	60/ -60	10/ -10	0.115/ 0.165	0.06/ 0.105	500/ 850	○

■ Thermal FET

Package code	Type No.	Ratings		Characteristics			Status
		V _{bss} (V)	I _D (A)	R _{DS(ON)} (Ω) max		T _{sd} (°C) typ	
				4 V (5 V)	10 V		
TO-220 AB	HAF1001	-60	-15	0.13	0.09	175	○
	HAF2001	60	20	0.065	0.043	175	○
TO-220 FM	HAF2002	60	20	0.065	0.043	175	○
	HAF2005	60	40	0.033	0.02	175	○
	HAF2008	60	20	0.065	0.044	175	SPL
LDBPAK	HAF1002(L)/(S)	-60	-15	0.13	0.09	175	○
	HAF1009(L)/(S)	-60	-40	0.045	0.027	175	SPL

	Type No.	Ratings		Characteristics			Status
				R _{DS(ON)} (Ω) max			
				4 V (5 V)	10 V		
LDBPAK	HAF2011(L)/(S)	60	40	0.033	0.02	175	○
	HAF2012(L)/(S)	60	20	0.065	0.043	175	○
	HAF2017(L)/(S)	60	20	0.065	0.043	175	SPL
	HAF2021(L)/(S)	60	50	0.015	0.012	175	○
DPAK	HAF1004(L)/(S)	-60	-5	0.34	0.2	175	SPL
	HAF2007(L)/(S)	60	5	0.12	0.075	175	○
SOP-8	HAF2015RJ	60	2	(0.2)	0.16	175	SPL

IGBT

■ General Switching

Package code	Type No.	Ratings		Characteristics		Status
		V _{CE(s)} (V)	I _C (A)	V _{CE(sat)} (V) typ	t _r (μs) typ	
TO-220 AB	2SH11	600	10	2.6	0.3	※
	2SH12	600	15	2.6	0.3	※
	2SH13	600	20	2.6	0.3	※
	2SH17	600	12	2.0	2.0	※
	2SH18	600	18	2.0	2.0	※
	2SH19	600	24	2.0	2.0	※
	2SH26	600	10	2.1	0.3	△
	2SH27	600	15	2.1	0.3	△
	2SH28	600	20	2.1	0.3	△
	2SH29	600	30	2.1	0.3	△

	Type No.	Ratings		Characteristics		Status
		V _{CE(s)} (V)	I _C (A)	V _{CE(sat)} (V) typ	t _r (μs) typ	
LDBPAK	GN2550V4 LD/LS	250	50	1.6	0.12	SPL
	GN6020V4 LD/LS	600	20	2.1	0.1	○
	GN6030V4 LD/LS	600	30	2.1	0.1	○
TO-3P	2SH14	600	30	2.6	0.3	△
	2SH15	600	50	2.6	0.3	△
	2SH20	600	36	2.0	2.0	△
	2SH21	600	50	2.0	2.0	※
	2SH30	600	50	2.1	0.3	△
	2SH31	600	75	2.1	0.3	△
	2SH32	600	75	2.1	0.3	△
TO-3PL	2SH16	600	75	2.6	0.3	○
	2SH22	600	75	2.0	2.0	※

RF POWER MODULE

■ High Frequency Amplification

Part No.	Package	Main Characteristics				Status
		f (MHz)	Pin (dBm)	Pout Min (dBm)	VDD (V)	
PF01410A	RF-K1	890~915	8	34.5	4.8	※
PF01411A	RF-K	880~915	0	35.8	4.8	※
PF01411B	RF-K-4	880~915	0	35.5	3.5	※
PF01412A	RF-K	890~915	0	35.8	5.5	※
PF04115B	RF-K2	1850~1910	0	32.5	3.5	※
PF0414A	RF-K	1710~1785	3	32.5	4.8	※
PF0414B	RF-K-4	1710~1785	0	32.5	3.5	※
PF08103A	RF-O	880~915 1710~1785	4.5	34.5 31.5	4.8	○
PF08103B	RF-O	880~915 1710~1785	1 4.5	35 32.5	3.5	○
PF08107B	RF-K-8	880~915 1710~1785	0	35 32	3.5	○
PF08107BP	RF-K-8	880~915 1710~1785	0	35 32.5	3.5	○
PF08109B	RF-O-12	880~915 1710~1785	0	35.5 32.7	3.5	○
PF08114B	RF-K1-10	880~915 1710~1785	10	34.5 31.5	3.5	○
PF08122B	RF-K-8	880~915 1710~1785	0	35 32.5	3.5	○
PF08123B	RF-K-8	880~915 1710~1785 1850~1910	0	35 32.5 32	3.5	○

注) ○: 正在批量生产
 SPL: 样品正在发货
 △: 可以批量生产 (交货期为三个月)
 ※: 限定品种

STANDARD TAPING SPECIFICATIONS

■ Packing Unit

Package code	Name Note)	Packing Unit	Package code	Name Note)	Packing Unit
TO-92	型号+等级+TZ	2500 Pcs/Box	TSSOP-14	型号+EL	1000 Pcs/Reel
TO-92 MOD	Type No.+Grade+TZ		(High frequency linear IC)	Type No.+EL	
SPAK			FP-8DA	型号+EL	2500 Pcs/Reel
MPAK	型号+标志+TL/TR	3000 Pcs/Reel	(JEDEC,SOP-8)	Type No.+EL	
MPAK-4	Type No.+Marking+TL/TR		LFPK	型号+EL	2500 Pcs/Reel
CMPAK				Type No.+EL	
CMPAK-4	型号+标志+UL/UR	12000 Pcs/Reel	TTP-8D	品名+EL	3000 Pcs/Reel
CMPAK-6	Type No.+Marking+UL/UR		(TSSOP-8)	Type No.+EL	
MPAK-5			DPAK S	型号+TL/TR	3000 Pcs/Reel
SMPAK				Type No.+TL/TR	
MFPK	型号+标志+TL/TR	9000 Pcs/Reel	LDPAK S	品名+TL/TR	1000 Pcs/Reel
	Type No.+Marking+TL/TR			Type No.+TL/TR	
SMFPAK-6	型号+标志+TL/TR	5000 Pcs/Reel	UPAK	型号+标志+TL/TR	1000 Pcs/Reel
	Type No.+Marking+TL/TR			Type No.+Marking+TL/TR	
EMFPAK-6	型号+标志+TL/TR	5000 Pcs/Reel		型号+标志+UL/UR	4000 Pcs/Reel
	Type No.+Marking+TL/TR			Type No.+Marking+UL/UR	
MPAK-5	型号+标志+EL	3000 Pcs/Reel	RP-8P	型号+标志+TB	1000 Pcs/Reel
MPAK-6	Type No.+Marking+EL			Type No.+Marking+TB	
(High frequency linear IC)				型号+标志+UB	4000 Pcs/Reel
TSOP-6	型号+EL	3000 Pcs/Reel		Type No.+Marking+UB	
CMFPAK-6	Type No.+EL				

Note) Lead (Pb) free: + "-E"

PACKAGE CODE

SPAK (JEITA:SC-72) **TO-92** (JEITA:SC-43A) **TO-92MOD** (JEITA:SC-51) **EMFPAK-6** **MFPAK** (1408扁平) **SMFPAK-6** **SMPAK** (JEITA:SC-75A) **CMPAK** (JEITA:SC-70) **CMPAK-4** (JEITA:SC-82AB)

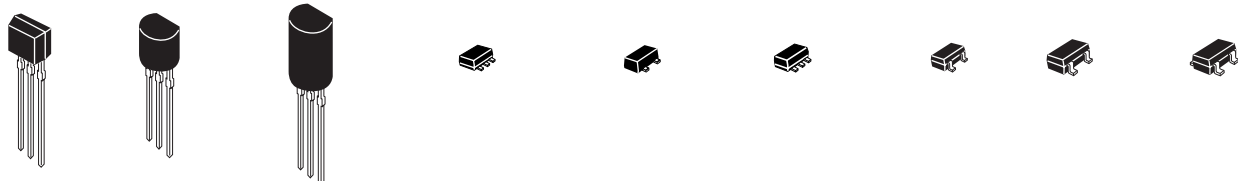

CMFPAK-6 **CMPAK-6** **MPAK** (JEITA:SC-59A) **MPAK-4** (JEITA:SC-61AA) **MPAK-5** **MPAK-6** **TSOP-6** **MSP-18**



TSSOP-14 **TNP-16BV** **UPAK** (JEITA:SC-62) **RP8P** **DPAK (L)** **DPAK (S)** (JEDEC SOP-8) **FP-8DA** (JEDEC SOP-8) **TTP-8D** (TSSOP-8) **TO-220AB**

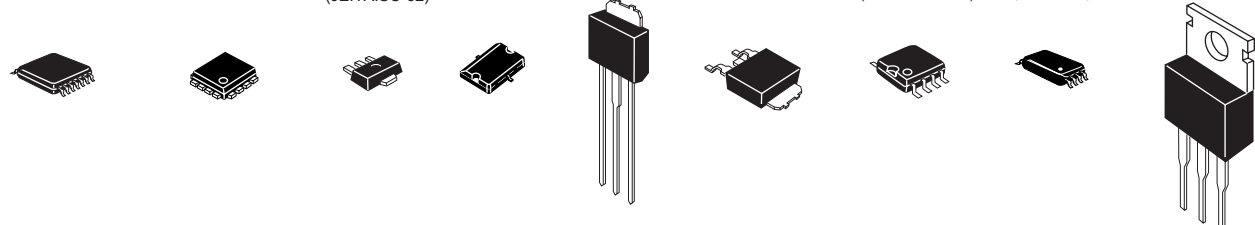

TO-220C **BFM** **TO-220FM** **TO-3P** **TO-3PFM** **TO-3PL** **LDBAK-(L)** **LDBAK-(S)** **LDBAK**

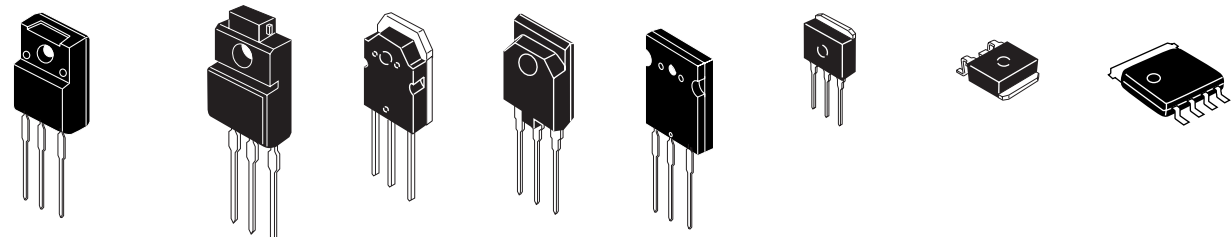

TRANSISTOR ARRAY
SP-10 **SP-12** **SP-12TA**

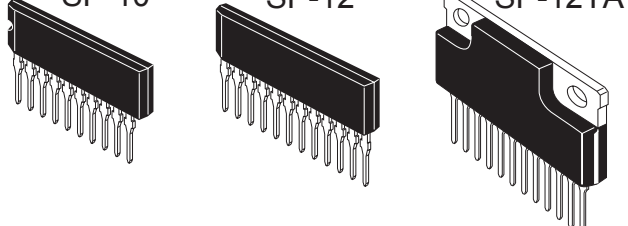

RF POWER TRANSISTOR

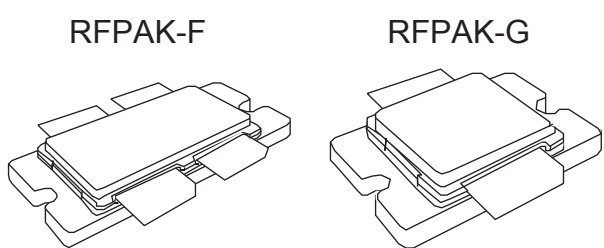

RF POWER MODULE

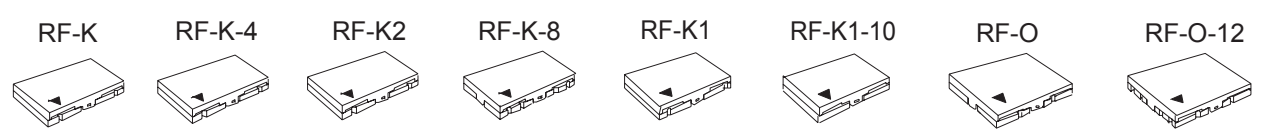

注) 上記外観図并非原寸大。

SURFACE MOUNT TYPE MARKING

■MPAK

Type No.	Marking
2SA1052	MB, MC, MD
2SA1121	SB, SC, SD
2SA1122	CC, CD, CE
2SA1171	PD, PE
2SA1484	IRD, IRE
2SA1566	JID, JIE
2SA1617	VIB, VIC
2SB831	BB, BC
2SB1691	WL-
2SC2462	LB, LC, LD
2SC2463	DD, DE, DF
2SC2618	RB, RC, RD
2SC2619	FA, FB, FC
2SC2620	QB, QC
2SC2732	EC
2SC2734	GC
2SC2735	JC
2SC2736	TC
2SC2776	VA, VB, VC
2SC3127	ID-
2SC3513	IS-
2SC3793	IP-
2SC4050	KID, KIE
2SC4196	QI-
2SC4197	TI-
2SC4366	ZI-
2SC4591	XM-
2SC4680	XU-
2SC4702	XV-
2SC4964	YV-
2SC5049	YA-
2SC5050	YZ-
2SC5218	YK-
2SC5772	FR-
2SC5773	JR-
2SD1101	AB, AC
2SD1306	ND, NE
2SD2655	WM-
2SJ399	ZF-
2SJ451	ZK-
2SJ452	ZM-
2SJ486	ZU-
2SJ574	BP
2SJ575	AP
2SK217	ZC, ZD, ZE
2SK360	IGD, IGE, IGF
2SK1070	PIB, PIC, PID, PIE
2SK2373	ZE-
2SK2569	ZN-
2SK2570	ZL-
2SK2802	ZV-
2SK2980	ZZ-
2SK3000	ZY-
2SK3287	AN
2SK3288	EN
2SK3290	BN
BRA114EMP	EG
BRA123EMP	JG
BRA124EMP	CG
BRA143EMP	GG
BRA144EMP	AG
BRC114EMP	FG
BRC123EMP	KG
BRC124EMP	DG
BRC143EMP	HG
BRC144EMP	BG

■MPAK-4

Type No.	Marking
2SC3957	GIA, GIB
2SC4926	YD-
2SC5080	ZD-
2SC5545	ZS-
3SK295	ZQ-
3SK297	ZP-
3SK300	ZR-
3SK319	YB-
BB101M	AU-
BB102M	BU-
BB301M	AW-
BB302M	BW-
BB303M	CW-
BB304M	DW-
BB305M	EW-
BB501M	AS-
BB502M	BS-
BB503M	CS-
BB504M	DS-
BIC702M	BZ-
BIC703M	CZ-

■MPAK-5

Type No.	Marking
HA22022	GDA (A: 制造月编码可变)
HA22033	GEA (A: 制造月编码可变)

■MPAK-6

Type No.	Marking
HA22040	GH

■SMPAK

Type No.	Marking
2SC5137	YA-
2SC5139	YZ-
2SC5247	ZD-
2SC5629	XZ-
2SJ587	DP
2SK3349	DN
H5N0301SM	GN
H5P0301SM	GP

■UPAK

Type No.	Marking
2SB1001	BH, BJ
2SB1002	CH, CJ
2SB1025	DH, DJ, DK
2SB1026	DL, DM
2SB1028	EL, EM
2SB1048	BT
2SC3380	AS
2SC4807	ER
2SC4988	FR
2SC5631	JR
2SD1367	BA, BB, BC
2SD1368	CA, CB, CC
2SD1418	DA, DB, DC
2SD1419	DD, DE

■UPAK

Type No.	Marking
2SD1421	ED, EE
2SD1470	AT
2SD1472	CT
2SD1974	ES
2SJ186	CY
2SJ244	JY
2SJ278	MY
2SJ317	NY
2SJ361	RY
2SJ484	WY
2SJ517	YY
2SJ518	AZ
2SK1334	BY
2SK1579	DY
2SK1697	EY
2SK1698	FY
2SK1764	KY
2SK1772	HY
2SK2247	QY
2SK2315	TY
2SK2788	VY
2SK2978	ZY
2SK3391	JX

■RP8P

Type No.	Marking
2SK3390	IX

■CMPAK

Type No.	Marking
2SA2080	MB, MC, MD
2SA2081	CC, CD, CE
2SC4260	TI-
2SC4261	QI-
2SC4262	IP-
2SC4264	GC
2SC4265	JC
2SC4463	HC
2SC4537	IS-
2SC4593	XM-
2SC4784	YA-
2SC4899	YH-
2SC4901	YK-
2SC4965	YV-
2SC5051	YZ-
2SC5850	LB, LC, LD
2SC5851	FA, FB, FC
2SJ576	AP
2SJ586	CP
2SK1215	IGD, IGE, IGF
2SK3289	AN
2SK3348	CN
2SK3378	EN
BRA114ECM	EG
BRA123ECM	JG
BRA124ECM	CG
BRA143ECM	GG
BRA144ECM	AG
BRC114ECM	FG
BRC123ECM	KG
BRC124ECM	DG
BRC143ECM	HG
BRC144ECM	BG

■CMPAK-4

Type No.	Marking
2SC4995	YD-
2SC5081	ZD-
2SC5593	XH-
2SC5594	XP-
2SC5623	WH-
2SC5624	VH-
2SC5820	WU-
2SC5894	WY-
2SK2685	ZT-
3SK296	ZQ-
3SK298	ZP-
3SK309	XV-
3SK317	ZR-
3SK318	YB-
BB101C	AU-
BB102C	BU-
BB301C	AW-
BB302C	BW-
BB303C	CW-
BB304C	DW-
BB305C	EW-
BB501C	AS-
BB502C	BS-
BB503C	CS-
BB504C	DS-
BIC702C	BZ-
BIC703C	CZ-

■CMPAK-6

Type No.	Marking
HAT1066G	66
HAT2106G	06
HAT3016G	16
TBB1001	AM
TBB1002	BM
TBB1004	DM
TBB1005	EM

■MFPK

Type No.	Marking
2SC5543	YA-
2SC5544	YZ-
2SC5554	YH-
2SC5555	ZD-
2SC5628	XZ-
2SC5700	WB-
2SC5702	ZS-
2SC5757	WE-
2SC5758	WF-
2SC5812	WG-
H5N0201MF	DN
H5N0301MF	GN
H5P0201MF	DP
H5P0301MF	GP

■CMFPK-6

Type No.	Marking
HAT1058C	058
HAT1059C	059
HAT1068C	068
HAT1069C	069

■SMFPK-6

Type No.	Marking
HTT1115S	EK
HTT1213S	CK

■EMFPK-6

Type No.	Marking
HTT1115E	F
HTT1213E	E